

## Mitsubishi Programmable Controller

MELSEC **Q** series MELSEC *L* series

# MELSEC-Q/L AnyWire DB A20 Master Module User's Manual

---

-QJ51AW12D2  
-LJ51AW12D2

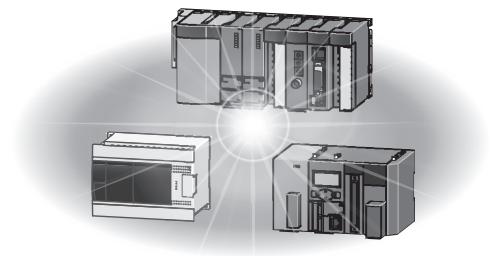

Powered by  
**Anywire**

This product was jointly developed and manufactured by Mitsubishi and Anywire Corporation.  
\*Note that the warranty on this product differs from that on other programmable controller products.  
(Refer to "WARRANTY" in this manual.)

***AnyWire DB A20***



# COPYRIGHT

This document is protected by the law of copyright, whereby all rights established therein remain with the company Mitsubishi Electric Corporation. Reproduction of this document or parts of this document is only permissible within the limits of the legal determination of Copyright Law. Alteration or abridgement of the document is not permitted without the explicit written approval of the company Mitsubishi Electric Corporation.

## PRECAUTIONS REGARDING WARRANTY AND SPECIFICATIONS

The QJ51AW12D2 and LJ51AW12D2 were jointly developed and manufactured by Mitsubishi and Anywire Corporation.

Note that there are some precautions regarding warranty and specifications of this product.

### <Warranty>

Item	QJ51AW12D2, LJ51AW12D2	Other programmable controller products (e.g. MELSEC-Q series)
Repair term after discontinuation of production	1 years	7 years

### <Specifications>

The general specifications of the QJ51AW12D2 are the same as those of other MELSEC-Q series except under the following condition.

When setting the transmission clock at 125kHz by using the module whose serial number (sixth digit) is 5 or earlier, apply within the following specified range:

Voltage range of external power supply: 21.6 to 25.2VDC

Operating ambient temperature: 0 to 50°C

The general specifications of the LJ51AW12D2 are the same as those of other MELSEC-L series.

### <Application of the EMC Directive>

Item	QJ51AW12D2	LJ51AW12D2	Other programmable controller products (e.g. MELSEC-Q series)
Applicable EMC standard	EN61131-2*1	EN61131-2	EN61131-2

\*1 The module with a serial number where the sixth digit is "3" or later complies with this standard.

<Application of the UL/cUL standards>

Item	QJ51AW12D2	LJ51AW12D2	Other programmable controller products (e.g. MELSEC-Q series)
Applicable UL standard/cUL standard	UL508 <sup>*2</sup> CSA22.2 <sup>*2</sup>	UL508 <sup>*3</sup> CSA22.2 <sup>*3</sup>	UL508 CSA22.2

\*2 The module with a serial number where the sixth digit is "4" or later complies with this standard.

\*3 The module with a serial number where the sixth digit is "2" or later complies with this standard.

# ● SAFETY PRECAUTIONS ●

(Read these precautions before using this product.)

Before using this product, please read this manual and the relevant manuals carefully and pay full attention to safety to handle the product correctly.

The precautions given in this manual are concerned with this product only. For the safety precautions of the programmable controller system, refer to the user's manual for the CPU module used.

In this manual, the safety precautions are classified into two levels: "⚠ WARNING" and "⚠ CAUTION".



Indicates that incorrect handling may cause hazardous conditions, resulting in death or severe injury.



Indicates that incorrect handling may cause hazardous conditions, resulting in minor or moderate injury or property damage.

Under some circumstances, failure to observe the precautions given under "⚠ CAUTION" may lead to serious consequences.

Observe the precautions of both levels because they are important for personal and system safety.

Make sure that the end users read this manual and then keep the manual in a safe place for future reference.

## When the QJ51AW12D2 is used

### [Design Precautions]

#### **WARNING**

- An AnyWire DB A20 system has no control function for ensuring safety.
- When connecting a peripheral with the programmable controller CPU or a personal computer with an intelligent function module to modify data of a running programmable controller, configure an interlock circuit in the sequence program to ensure that the entire system will always operate safely. For other forms of control (such as program modification or operating status change) of a running programmable controller, read the relevant manuals carefully and ensure that the operation is safe before proceeding. Especially, when a remote programmable controller is controlled by an external device, immediate action cannot be taken if a problem occurs in the programmable controller due to a communication failure. To prevent this, configure an interlock circuit in the sequence program, and determine corrective actions to be taken between the external device and CPU module in case of a communication failure.
- Do not write any data to the "system area" of the buffer memory in the intelligent function module. Also, do not use any "use prohibited" signals as an output signal from the programmable controller CPU to the intelligent function module. Doing so may cause malfunction of the programmable controller system.

### [Design Precautions]

#### **CAUTION**

- Although an AnyWire DB A20 system features high noise immunity, keep a distance of 100mm or more between the transmission cables or I/O cables and the high-voltage cables or power cables. Failure to do so may cause malfunction.
- Configure safety circuits, such as an emergency stop circuit and interlock circuit, external to the AnyWire DB A20 system.

## [Installation Precautions]

### **WARNING**

- Use the programmable controller in an environment that meets the general specifications in the user's manual for the CPU module used.  
Failure to do so may result in electric shock, fire, malfunction, or damage to or deterioration of the product.
- To mount the module, while pressing the module mounting lever located in the lower part of the module, fully insert the module fixing projection(s) into the hole(s) in the base unit and press the module until it snaps into place.  
Incorrect interconnection may cause malfunction, failure, or drop of the module.  
When using the programmable controller in an environment of frequent vibrations, fix the module with a screw.  
Tighten the screw within the specified torque range.  
Undertightening can cause drop of the screw, short circuit, or malfunction.  
Overtightening can damage the screw and/or module, resulting in drop, short circuit, or malfunction.
- Shut off the external power supply (all phases) used in the system before mounting or removing a module.  
Failure to do so may result in damage to the product.
- Do not directly touch any conductive parts and electronic components of the module.  
Doing so can cause malfunction or failure of the module.

## [Wiring Precautions]

### CAUTION

- Tighten the terminal screw within the specified torque range.  
Undertightening can cause short circuit, fire or malfunction.  
Overtightening can damage the screw and/or module, resulting in drop, short circuit, or malfunction.
- Prevent foreign matter such as dust or wire chips from entering the module.  
Such foreign matter can cause a fire, failure, or malfunction.
- A protective film is attached to the top of the module to prevent foreign matter, such as wire chips, from entering the module during wiring.  
Do not remove the film during wiring.  
Remove it for heat dissipation before system operation.
- Incorrect wiring may damage modules and external devices.  
Adjust a cable length and a module position to prevent disconnection of a connector type terminal block or a cable.
- Do not solder stranded wires of a cable when connecting them to the terminal block. Doing so may cause poor contact.
- The power supply voltage of remote slave modules may be insufficient due to a voltage drop in the power supply line. Connect an external power supply so that the voltage of remote slave modules is ensured.
- Do not apply the 24VDC power before wiring the entire AnyWire DB A20 system.
- Use 24VDC stabilized power supplies for devices in the AnyWire DB A20 system.
- Do not install the control lines or communication cables together with the main circuit lines or power cables.  
Failure to do so may result in malfunction due to noise.
- Place the cables in a duct or clamp them.  
If not, dangling cable may swing or inadvertently be pulled, resulting in damage to the module or cables or malfunction due to poor contact.
- When disconnecting the cable from the module, do not pull the cable by the cable part.  
For the cable connected to the terminal block, loosen the terminal screw.  
Pulling the cable connected to the module may result in malfunction or damage to the module or cable.



## [Startup and Maintenance Precautions]

### **WARNING**

- Do not touch any terminal while power is on. Doing so will cause electric shock or malfunction.
- Shut off the external power supply (all phases) used in the system before cleaning the module or retightening the terminal screws or module fixing screws.  
Failure to do so may result in electric shock.  
Undertightening the terminal screws can cause short circuit or malfunction.  
Overtightening can damage the screw and/or module, resulting in drop, short circuit, or malfunction.

## [Startup and Maintenance Precautions]

### **CAUTION**

- Do not disassemble or modify the modules. Doing so may cause failure, malfunction, injury, or a fire.
- Shut off the external power supply (all phases) used in the system before mounting or removing a module.  
Failure to do so may cause the module to fail or malfunction.
- After the first use of the product, do not mount/remove the module to/from the base unit, and the terminal block to/from the module more than 50 times (IEC 61131-2 compliant) respectively.  
Exceeding the limit of 50 times may cause malfunction.
- Before handling the module, touch a grounded metal object to discharge the static electricity from the human body.  
Failure to do so may cause the module to fail or malfunction.

## [Disposal Precautions]

### **CAUTION**

- When disposing of this product, treat it as industrial waste.

## When the LJ51AW12D2 is used

### [Design Precautions]

#### **WARNING**

- An AnyWire DB A20 system has no control function for ensuring safety.
- When connecting a peripheral with the CPU module or a personal computer with an intelligent function module to modify data of a running programmable controller, configure an interlock circuit in the sequence program to ensure that the entire system will always operate safely. For other forms of control (such as program modification or operating status change) of a running programmable controller, read the relevant manuals carefully and ensure that the operation is safe before proceeding. Especially, when a remote programmable controller is controlled by an external device, immediate action cannot be taken if a problem occurs in the programmable controller due to a communication failure. To prevent this, configure an interlock circuit in the sequence program, and determine corrective actions to be taken between the external device and CPU module in case of a communication failure.
- Do not write any data to the "system area" of the buffer memory in the intelligent function module. Also, do not use any "use prohibited" signals as an output signal from the programmable controller CPU to the intelligent function module. Doing so may cause malfunction of the programmable controller system.

### [Design Precautions]

#### **CAUTION**

- Do not install the control lines or communication cables together with the main circuit lines or power cables.  
Keep a distance of 100mm or more between them. Failure to do so may result in malfunction due to noise.
- Configure safety circuits, such as an emergency stop circuit and interlock circuit, external to the AnyWire DB A20 system.

## [Installation Precautions]

### **WARNING**

- Shut off the external power supply (all phases) used in the system before mounting or removing the module.  
Failure to do so may result in electric shock or cause the module to fail or malfunction.

## [Installation Precautions]

### **CAUTION**

- Use the programmable controller in an environment that meets the general specifications in the Safety Guidelines provided with the CPU module or head module. Failure to do so may result in electric shock, fire, malfunction, or damage to or deterioration of the product.
- To interconnect modules, engage the respective connectors and securely lock the module joint levers. Incorrect interconnection may cause malfunction, failure, or drop of the module.
- Tighten the screws within the specified torque range. Undertightening can cause drop of the screw, short circuit, or malfunction. Overtightening can damage the screw and/or module, resulting in drop, short circuit, or malfunction.
- Do not directly touch any conductive parts and electronic components of the module. Doing so can cause malfunction or failure of the module.

## [Wiring Precautions]

### CAUTION

- Tighten the terminal screw within the specified torque range.  
Undertightening can cause short circuit, fire or malfunction.  
Overtightening can damage the screw and/or module, resulting in drop, short circuit, or malfunction.
- Prevent foreign matter such as dust or wire chips from entering the module.  
Such foreign matter can cause a fire, failure, or malfunction.
- A protective film is attached to the top of the module to prevent foreign matter, such as wire chips, from entering the module during wiring.  
Do not remove the film during wiring.  
Remove it for heat dissipation before system operation.
- Incorrect wiring may damage modules and external devices.  
Adjust a cable length and a module position to prevent disconnection of a connector type terminal block or a cable.
- Do not solder stranded wires of a cable when connecting them to the terminal block. Doing so may cause poor contact.
- The power supply voltage of remote slave modules may be insufficient due to a voltage drop in the power supply line. Connect an external power supply so that the voltage of remote slave modules is ensured.
- Do not apply the 24VDC power before wiring the entire AnyWire DB A20 system.
- Use 24VDC stabilized power supplies for devices in the AnyWire DB A20 system.
- Do not install the control lines or communication cables together with the main circuit lines or power cables.  
Failure to do so may result in malfunction due to noise.
- Place the cables in a duct or clamp them.  
If not, dangling cable may swing or inadvertently be pulled, resulting in damage to the module or cables or malfunction due to poor contact.
- When disconnecting the cable from the module, do not pull the cable by the cable part.  
For the cable connected to the terminal block, loosen the terminal screw.  
Pulling the cable connected to the module may result in malfunction or damage to the module or cable.

## [Startup and Maintenance Precautions]

### **WARNING**

- Do not touch any terminal while power is on. Doing so will cause electric shock or malfunction.
- Shut off the external power supply (all phases) used in the system before cleaning the module or retightening the terminal block screws. Failure to do so may result in electric shock.

## [Startup and Maintenance Precautions]

### **CAUTION**

- Do not disassemble or modify the module.  
Doing so may cause failure, malfunction, injury, or a fire.
- Shut off the external power supply (all phases) used in the system before mounting or removing a module.  
Failure to do so may cause the module to fail or malfunction.
- Tighten the terminal block screws within the specified torque range. Undertightening can cause drop of the component or wire, short circuit, or malfunction. Overtightening can damage the screw and/or module, resulting in drop, short circuit, or malfunction.
- After the first use of the product (module, display unit, and terminal block), the number of connections/disconnections is limited to 50 times (in accordance with IEC 61131-2).  
Exceeding the limit may cause malfunction.
- Before handling the module, touch a conducting object such as a grounded metal to discharge the static electricity from the human body.  
Failure to do so may cause the module to fail or malfunction.

## [Disposal Precautions]

### **CAUTION**

- When disposing of this product, treat it as industrial waste.

# ●CONDITIONS OF USE FOR THE PRODUCT●

- (1) Mitsubishi programmable controller ("the PRODUCT") shall be used in conditions;
- i) where any problem, fault or failure occurring in the PRODUCT, if any, shall not lead to any major or serious accident; and
  - ii) where the backup and fail-safe function are systematically or automatically provided outside of the PRODUCT for the case of any problem, fault or failure occurring in the PRODUCT.
- (2) The PRODUCT has been designed and manufactured for the purpose of being used in general industries. MITSUBISHI SHALL HAVE NO RESPONSIBILITY OR LIABILITY (INCLUDING, BUT NOT LIMITED TO ANY AND ALL RESPONSIBILITY OR LIABILITY BASED ON CONTRACT, WARRANTY, TORT, PRODUCT LIABILITY) FOR ANY INJURY OR DEATH TO PERSONS OR LOSS OR DAMAGE TO PROPERTY CAUSED BY the PRODUCT THAT ARE OPERATED OR USED IN APPLICATION NOT INTENDED OR EXCLUDED BY INSTRUCTIONS, PRECAUTIONS, OR WARNING CONTAINED IN MITSUBISHI'S USER, INSTRUCTION AND/OR SAFETY MANUALS, TECHNICAL BULLETINS AND GUIDELINES FOR the PRODUCT.

## ("Prohibited Application")

Prohibited Applications include, but not limited to, the use of the PRODUCT in;

- Nuclear Power Plants and any other power plants operated by Power companies, and/or any other cases in which the public could be affected if any problem or fault occurs in the PRODUCT.
- Railway companies or Public service purposes, and/or any other cases in which establishment of a special quality assurance system is required by the Purchaser or End User.
- Aircraft or Aerospace, Medical applications, Train equipment, transport equipment such as Elevator and Escalator, Incineration and Fuel devices, Vehicles, Manned transportation, Equipment for Recreation and Amusement, and Safety devices, handling of Nuclear or Hazardous Materials or Chemicals, Mining and Drilling, and/or other applications where there is a significant risk of injury to the public or property.

Notwithstanding the above, restrictions Mitsubishi may in its sole discretion, authorize use of the PRODUCT in one or more of the Prohibited Applications, provided that the usage of the PRODUCT is limited only for the specific applications agreed to by Mitsubishi and provided further that no special quality assurance or fail-safe, redundant or other safety features which exceed the general specifications of the PRODUCTS are required. For details, please contact the Mitsubishi representative in your region.

# COMPLIANCE WITH EMC AND LOW VOLTAGE DIRECTIVES

---

## **(1) Method of ensuring compliance**

To ensure that Mitsubishi programmable controllers maintain EMC and Low Voltage Directives when incorporated into other machinery or equipment, certain measures may be necessary. Please refer to one of the following manuals.

- User's manual for the CPU module or head module used
- Safety Guidelines (This manual is included with the CPU module or base unit.)

The CE mark on the side of the programmable controller indicates compliance with EMC and Low Voltage Directives.

## **(2) Additional measures**

To ensure that this product maintains EMC and Low Voltage Directives, please refer to Page 73, Appendix 1.

# CONTENTS

COPYRIGHT .....	1
PRECAUTIONS REGARDING WARRANTY AND SPECIFICATIONS .....	1
SAFETY PRECAUTIONS .....	3
CONDITIONS OF USE FOR THE PRODUCT .....	12
COMPLIANCE WITH EMC AND LOW VOLTAGE DIRECTIVES .....	13
TERMS .....	16
<hr/>	
<b>CHAPTER 1 OVERVIEW</b>	<b>17</b>
<hr/>	
<b>CHAPTER 2 SPECIFICATIONS</b>	<b>19</b>
<hr/>	
2.1 General Specifications .....	19
2.2 Performance Specifications .....	20
2.2.1 Performance specifications .....	20
2.2.2 Power supply sequence and handling of I/O data .....	21
2.3 Applicable System .....	22
2.3.1 QJ51AW12D2 .....	22
2.3.2 LJ51AW12D2 .....	23
2.4 External Dimensions .....	24
2.5 Part Names .....	26
2.6 Module Mounting .....	27
2.7 Checking Function Version and Serial Number .....	28
<hr/>	
<b>CHAPTER 3 OPERATION MODE</b>	<b>29</b>
<hr/>	
3.1 QJ51AW12D2 .....	29
3.1.1 Transmission speed setting .....	29
3.1.2 Setting of the number of transmission points, double check mode, and waveform output method .....	31
3.2 LJ51AW12D2 .....	37
3.2.1 Setting of the number of transmission points .....	39
3.2.2 Transmission speed setting .....	40
3.2.3 Double check mode setting .....	41
3.2.4 Waveform output method setting .....	43
<hr/>	
<b>CHAPTER 4 PROGRAMMING</b>	<b>44</b>
<hr/>	
4.1 I/O Signals with CPU Module .....	44
4.1.1 I/O signal list .....	44
4.1.2 Details of the input signal .....	45
4.1.3 Details of the output signal .....	45
4.2 Buffer Memory Area .....	46
4.2.1 I/O area .....	47
4.2.2 Number of error addresses .....	48
4.2.3 Value of error addresses .....	48
4.2.4 Number of connection addresses .....	49
4.2.5 Value of connection addresses .....	49
4.2.6 Latest error code storage area, latest error ID storage area .....	49
4.3 Program Example .....	50



---

**CHAPTER 5 MONITORING FUNCTION** 52

---

5.1	Automatic Address Detection	53
5.1.1	Automatic address detection operation	53
5.2	Monitoring Operation	54

---

**CHAPTER 6 LED DISPLAY** 55

---

6.1	QJ51AW12D2	55
6.2	LJ51AW12D2	56

---

**CHAPTER 7 CONNECTIONS** 57

---

7.1	Description of Terminals	57
7.2	Transmission Cable Terminal Block	58
7.3	Cable Processing	59
7.4	Terminating Unit	60

---

**CHAPTER 8 TRANSMISSION TIME** 61

---

8.1	Transmission Cycle Time	61
8.1.1	Transmission cycle time of the master module	61
8.1.2	Effects of the double check system	62
8.2	Transmission Delay Time	63
8.2.1	Slave module (input) to master module	63
8.2.2	Master module to slave module (output)	64

---

**CHAPTER 9 TROUBLESHOOTING** 65

---

9.1	Visual Inspection	65
9.2	Check with Input Signals	67
9.3	Troubleshooting of Master Module	68
9.3.1	QJ51AW12D2	68
9.3.2	LJ51AW12D2	69
9.4	Troubleshooting of Slave Module	71
9.5	List of Error Codes	72

---

**APPENDICES** 73

---

Appendix 1	EMC and Low Voltage Directives	73
Appendix 1.1	Requirements for compliance with the EMC Directive	73
Appendix 1.2	Requirements for compliance with the Low Voltage Directive	75
Appendix 2	Differences between the QJ51AW12D2 and LJ51AW12D2	76
Appendix 3	Functions Added and Modified with Version Upgrade	77
REVISIONS		78
WARRANTY		79
TRADEMARKS		80

# TERMS

Unless otherwise specified, this manual uses the following terms.

Term	Description
Master module	A generic term for the QJ51AW12D2 and LJ51AW12D2 A module that controls a data link system. One master module is required for one system.
QJ51AW12D2	The abbreviation for the AnyWire DB A20 master module, QJ51AW12D2
LJ51AW12D2	The abbreviation for the AnyWire DB A20 master module, LJ51AW12D2
MELSEC-Q series	The abbreviation for the Mitsubishi programmable controller MELSEC-Q series
MELSEC-L series	The abbreviation for the Mitsubishi programmable controller MELSEC-L series
Programmable controller CPU	The abbreviation for the MELSEC-Q series CPU module and MELSEC-L series CPU module
Intelligent function module	A MELSEC-Q/L series module other than CPU modules, power supply modules, and I/O modules, which is mounted on a base unit
Remote I/O module	A module that communicates I/O data with a master module
Programming tool	A generic term for GX Works2 and GX Developer
GX Works2	The product name of the software package for the MELSEC programmable controllers
GX Developer	
AnyWire DB A20	An original transmission system provided by Anywire Corporation. The full-duplex transmission mode enables a high-speed and long-distance communication. This system provides a high-speed and highly-reliable sensor network.
Slave module	A generic term for modules that communicate data with a master module
Bridge module	A module that serves as a master module in a transmission system such as OpenBus
Terminating unit	A waveform shaper
Transmission cycle time	A data sampling interval
Buffer memory	A memory in an intelligent function module, where data (such as setting values and monitoring values) exchanged with a CPU module are stored

# CHAPTER 1 OVERVIEW

This manual describes the specifications, part names, and settings of the QJ51AW12D2 AnyWire DB A20 master module (hereafter abbreviated as the QJ51AW12D2) and LJ51AW12D2 AnyWire DB A20 master module (hereafter abbreviated as the LJ51AW12D2).

This module, a product of the joint development project with Anywire Corporation, allows the AnyWire sensor network system to be constructed in a MELSEC-Q series or MELSEC-L series programmable controller system.

The AnyWire DB A20 system is a high-speed and highly reliable sensor network system.

## <Features of AnyWire DB A20>

The transmission distance can be selected from 50m/200m/1km/3km using the DIP switch.

Up to 512 remote input points and 512 remote output points can be controlled by one QJ51AW12D2 or LJ51AW12D2 (in the standard setting).

Disconnections can be detected even when the wiring is branched.

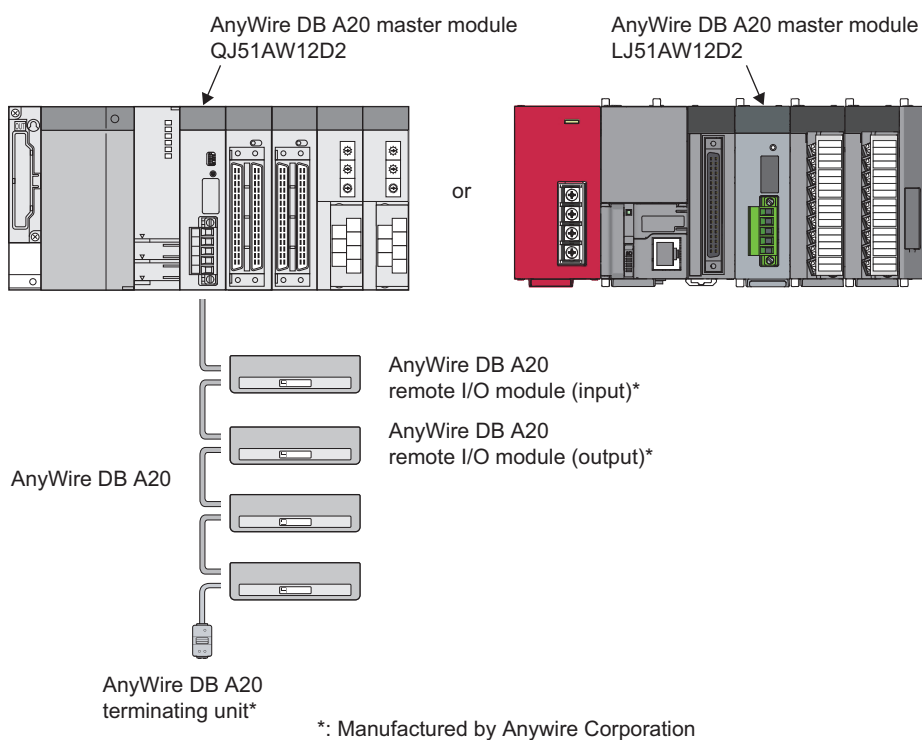

## <Configuration of the AnyWire DB A20 system>

The following table lists the maximum number of connectable modules in one AnyWire DB A20 system.

Module	The maximum number of connectable modules
Master module	1
Slave module	128

# Memo

---

# CHAPTER 2 SPECIFICATIONS

## 2.1 General Specifications

Item	Specifications					
Operating ambient temperature	0 to 55°C*4					
Storage ambient temperature	-25 to 75°C					
Operating ambient humidity	5 to 95%RH, non-condensing					
Storage ambient humidity						
Vibration resistance	Compliant with JIS B 3502 and IEC 61131-2	Under intermittent vibration	Frequency	Constant acceleration	Half amplitude	No. of sweeps
			5 to 8.4Hz	—	3.5mm	
		Under continuous vibration	8.4 to 150Hz	9.8m/s <sup>2</sup>	—	10 times each in X, Y, and Z directions
			5 to 8.4Hz	—	1.75mm	—
8.4 to 150Hz	4.9m/s <sup>2</sup>	—	—	—		
Shock resistance	Compliant with JIS B 3502 and IEC 61131-2 (147 m/s <sup>2</sup> , 3 times each in X, Y, and Z directions)					
Operating atmosphere	No corrosive gas					
Operating altitude*1	0 to 2000m					
Installation location	Inside the control panel					
Overvoltage category*2	II or less					
Pollution degree*3	2 or less					
Equipment class	Class I					

- \*1 Do not use or store the programmable controller under pressure higher than the atmospheric pressure at sea level. Doing so may cause malfunction.  
When using the programmable controller under pressure, please consult your local Mitsubishi representative.
- \*2 This indicates the section of the power supply to which the equipment is assumed to be connected between the public electrical power distribution network and the machinery within premises.  
Category II applies to equipment for which electrical power is supplied from fixed facilities.  
The surge voltage withstand level for up to the rated voltage of 300 V is 2500 V.
- \*3 This index indicates the degree to which conductive material is generated in terms of the environment in which the equipment is used.  
In pollution degree 2, only non-conductive pollution occurs. A temporary conductivity caused by an accidental condensation may also occur occasionally.
- \*4 When the transmission clock of the QJ51AW12D2 whose serial number (sixth digit) is 5 or earlier is set to 125kHz, use within the following specified range.
- External power supply voltage range: 21.6VDC to 25.2VDC
  - Operating ambient temperature: 0 to 50°C

## 2.2 Performance Specifications

### 2.2.1 Performance specifications

Item	Specifications							
	QJ51AW12D2				LJ51AW12D2			
Transmission clock	125kHz <sup>*3</sup>	31.3kHz	7.8kHz	2kHz	125kHz	31.3kHz	7.8kHz	2kHz
Maximum transmission distance (Total length)	50m	200m	1km	3km	50m	200m	1km	3km
Number of connected modules	Up to 128	Up to 128	Up to 128	Up to 32 <sup>*1</sup>	Up to 128	Up to 128	Up to 128	Up to 32 <sup>*1</sup>
Transmission system	Cyclic transmission with full-duplex mode							
Connection type	Bus topology (Multidrop system, T-branch system, tree branch system)							
Transmission protocol	Dedicated protocol (AnyWire DB A20)							
Error control	Double check system							
Number of connected I/O points	Up to 1024 points (512 input points/512 output points) (However, up to 1024 input points/1024 output points can be set) <sup>*2</sup>							
RAS function	Disconnected transmission cable location detection function, transmission cable short detection function, transmission cable power supply voltage drop detection function							
DB A20 transmission cable	<ul style="list-style-type: none"> <li>UL-compliant general-purpose 2-/4-wire cable (VCTF, VCT 0.75 to 1.25mm<sup>2</sup>, rated temperature 70°C or higher)</li> <li>UL-compliant general-purpose wire (0.75 to 1.25mm<sup>2</sup>, rated temperature 70°C or higher)</li> <li>FK4-UL075-100 (AnyWire) (0.75mm<sup>2</sup>, rated temperature 90°C) (UL-compliant item)</li> </ul> <p>(Regardless of the type of the transmission cable, when the transmission distance exceeds 200m, use wires with a diameter of 0.9 to 1.25mm<sup>2</sup>.)</p>							
24VDC power cable	<ul style="list-style-type: none"> <li>UL-compliant general-purpose 2-wire cable (VCTF, VCT 0.75 to 2.0mm<sup>2</sup>, rated temperature 70°C or higher)</li> <li>UL-compliant general-purpose wire (0.75 to 2.0mm<sup>2</sup>, rated temperature 70°C or higher)</li> <li>FK4-UL075-100 (AnyWire) (0.75mm<sup>2</sup>, rated temperature 90°C) (UL-compliant item)</li> </ul>							
Power supply <sup>*3</sup>	Circuit: (Supplied from the Q bus side) Voltage +5V±5%, Current 0.5A max. Transmission cable: Voltage 24VDC +15 to -10% (21.6 to 27.6VDC), ripple voltage 0.5Vp-p or lower Current 0.5A (When 128 slave modules are connected and the load current is not included)				Circuit: (Supplied from the L bus side) Voltage +5V±5%, Current 0.2A max. Transmission cable: Voltage 24VDC +15 to -10% (21.6 to 27.6VDC), ripple voltage 0.5Vp-p or lower Current 0.5A (When 128 slave modules are connected and the load current is not included)			
Number of I/O occupied points	32 points (I/O assignment: intelligent 32 points)							
Number of writes to EEPROM	100000 times (maximum)							
External dimensions	98 mm (H) × 27.4 mm (W) × 100 mm (D)				90mm (H) × 28.5mm (W) × 104.5mm (D)			
Weight	0.11kg				0.2kg			

\*1 Up to 64 modules can be connected within 2km.

\*2 Used when required in special situations.

\*3 When the transmission clock of the QJ51AW12D2 whose serial number (sixth digit) is 5 or earlier is set to 125kHz, use within the following specified range.

- External power supply voltage range: 21.6VDC to 25.2VDC
- Operating ambient temperature: 0 to 50°C

## 2.2.2 Power supply sequence and handling of I/O data

An incorrect input/output may occur depending on the supply procedure of the power of the master module, the external power supply for transmission line, and the external power supply for slave module. Pay attention to the following points.

- The master module requires 2 seconds of elapsed time after power-on (the power supply of the programmable controller). Therefore, do not make any access related to this module (X, Y, or FROM/ TO) for 2 seconds after the programmable controller is powered on.
- Follow the procedure of powering on the programmable controller. Power on the programmable controller, then power on the external power supply.
- Depending on how to supply the external power supply, D/G terminal disconnection (Xn4) may turn on (the "ALM" LED may turn on) during initial processing. Therefore, turn on (500ms or more) and off Disconnection flag reset command output (Yn0) at the start of access.

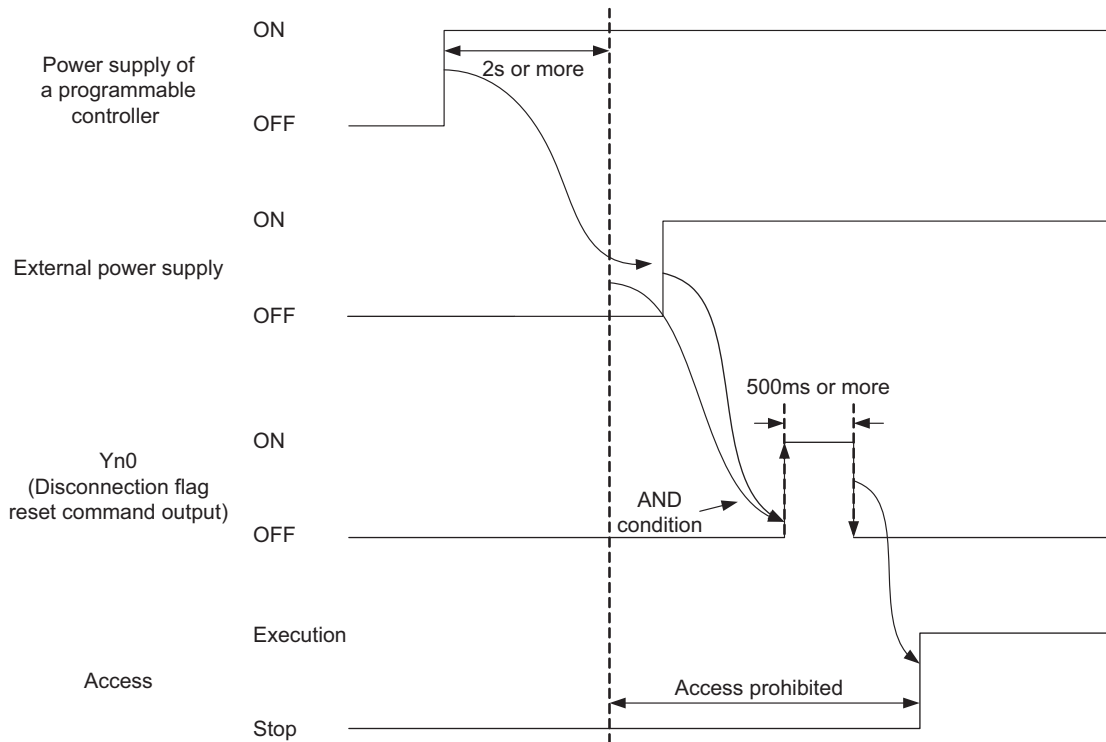

## 2.3 Applicable System

### 2.3.1 QJ51AW12D2

#### (1) Mountable modules and the number of mountable modules

The applicable CPU module, network module, and the number of mountable modules for the QJ51AW12D2 are shown below.

Insufficient power capacity may occur depending on the combination of other modules and the number of mountable modules.

When mounting the modules, consider the power capacity.

If the power capacity is insufficient, reconsider the combination of the mounted modules.

Connectable module		Base unit mountability	Number of mountable modules	
Module type	Model name			
CPU module	Basic model QCPU	Q00JCPU	Up to 8	
		Q00CPU, Q01CPU	Up to 24	
	High Performance model QCPU	Q02CPU, Q02HCPU, Q06HCPU, Q12HCPU, Q25HCPU	○	Up to 64
	Universal model QCPU	Q00UJCPU	○	Up to 8
		Q00UCPU, Q01UCPU		Up to 24
		Q02UCPU		Up to 36
		Q03UDCPU, Q04UDHCPU, Q06UDHCPU, Q10UDHCPU, Q13UDHCPU, Q20UDHCPU, Q26UDHCPU		Up to 64
		Q03UDECPU, Q04UDEHCPU, Q06UDEHCPU, Q10UDEHCPU, Q13UDEHCPU, Q20UDEHCPU, Q26UDEHCPU, Q50UDEHCPU, Q100UDEHCPU		
	Process CPU	Q02PHCPU, Q06PHCPU, Q12PHCPU, Q25PHCPU	○	Up to 64
	Redundant CPU	Q12PRHCPU, Q25PRHCPU	△	Up to 53
C controller module	Q06CCPU-V-B, Q06CCPU-V, Q06CCPU-V-H01, Q12DCCPU-V	○	Up to 64	
	Q24DHCCPU-V	○	Up to 62	
Network module	QJ72LP25-25, QJ72LP25G, QJ72LP25GE, QJ72BR15	○	Up to 64	

○: Can be mounted, △: Cannot be mounted to the main base unit, can be mounted to the extension base unit

#### (2) Compatibility with multiple CPU system

The QJ51AW12D2 supports the multiple CPU system from its first product.

When using the QJ51AW12D2 in the multiple CPU system, refer to the following manual.

- QCPU User's Manual (Multiple CPU System)



## 2.3.2 LJ51AW12D2

### (1) Mountable modules and the number of mountable modules

The applicable CPU module, head module, and the number of mountable modules for the LJ51AW12D2 are shown below.

The number of extension blocks differs depending on the CPU module or the head module to be used.

The head module cannot configure an extension system.

Mountable module		Number of extension blocks	Number of mountable modules <sup>*1</sup>	Maximum configuration <sup>*2</sup>
Module type	Model name			
CPU module	L02SCPU, L02SCPU-P, L02CPU, L02CPU-P	2 blocks maximum	Main block: 10 modules maximum Extension block: 11 modules maximum	30 modules • Main block: 9 modules • Extension block 1: 10 modules • Extension block 2: 11 modules
	L06CPU, L06CPU-P, L26CPU, L26CPU-P, L26CPU-BT, L26CPU-PBT	3 blocks maximum		40 modules • Main block: 9 modules • Extension block 1: 10 modules • Extension block 2: 10 modules • Extension block 3: 11 modules
Head module	LJ72GF15-T2	Not expandable	10 modules maximum	10 modules maximum

\*1 Power supply module, CPU module, display unit, extension module, RS-232 adapter, RS-422/485 adapter, and END cover are excluded.

\*2 Total of mountable I/O modules, intelligent function modules, and network modules.

## 2.4 External Dimensions

(1) QJ51AW12D2

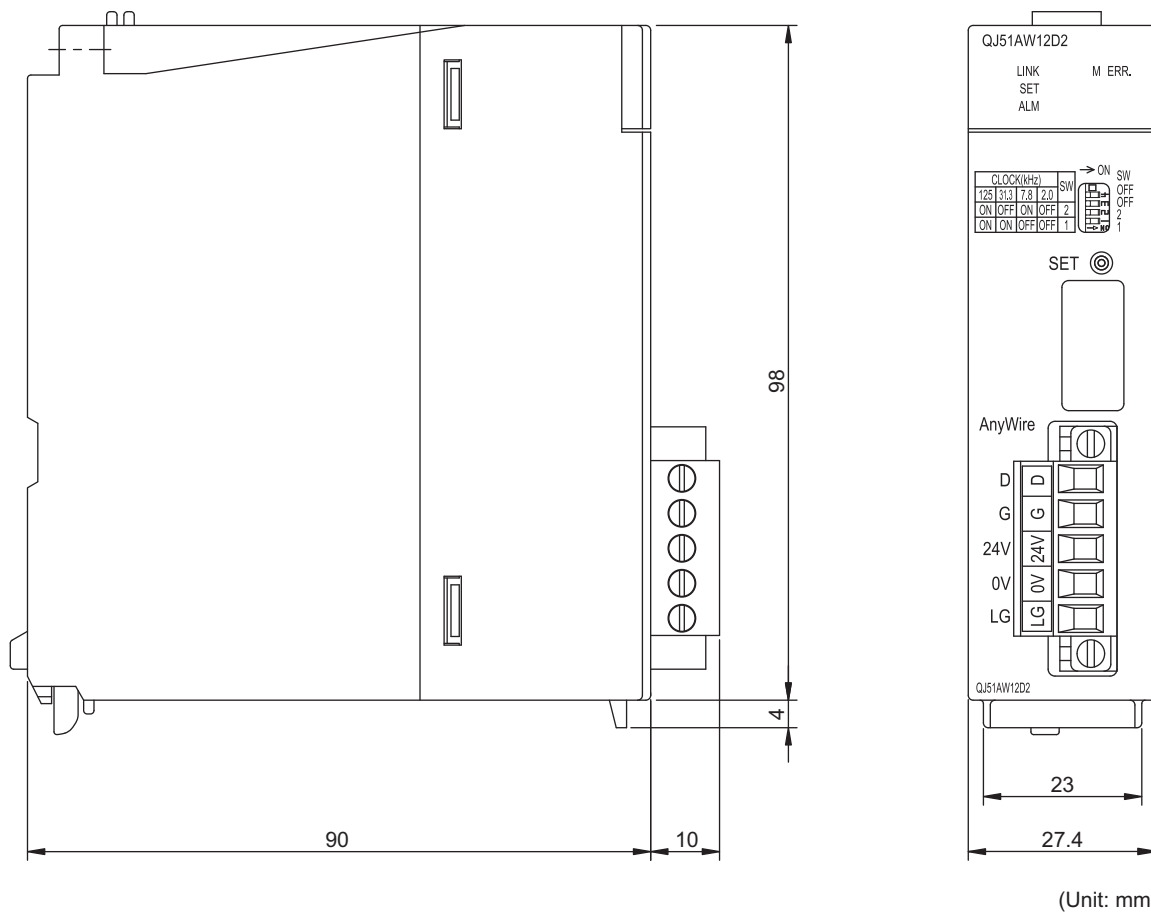

(Unit: mm)

(2) LJ51AW12D2

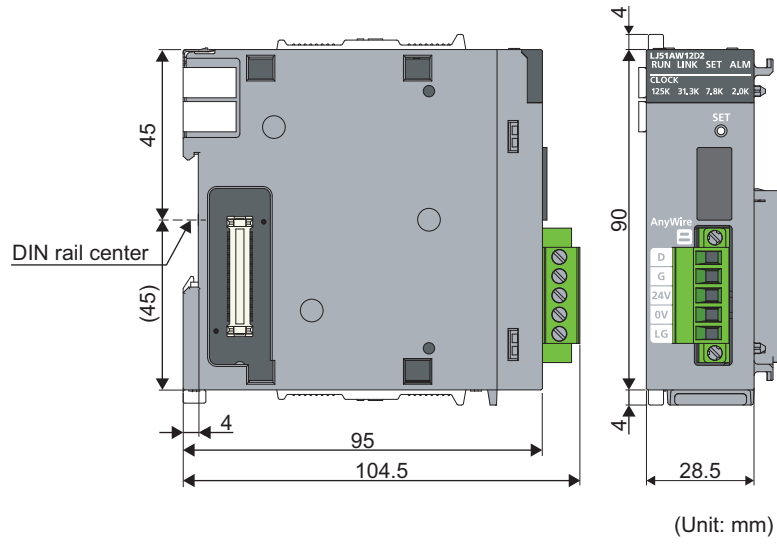

2

2.4 External Dimensions

## 2.5 Part Names

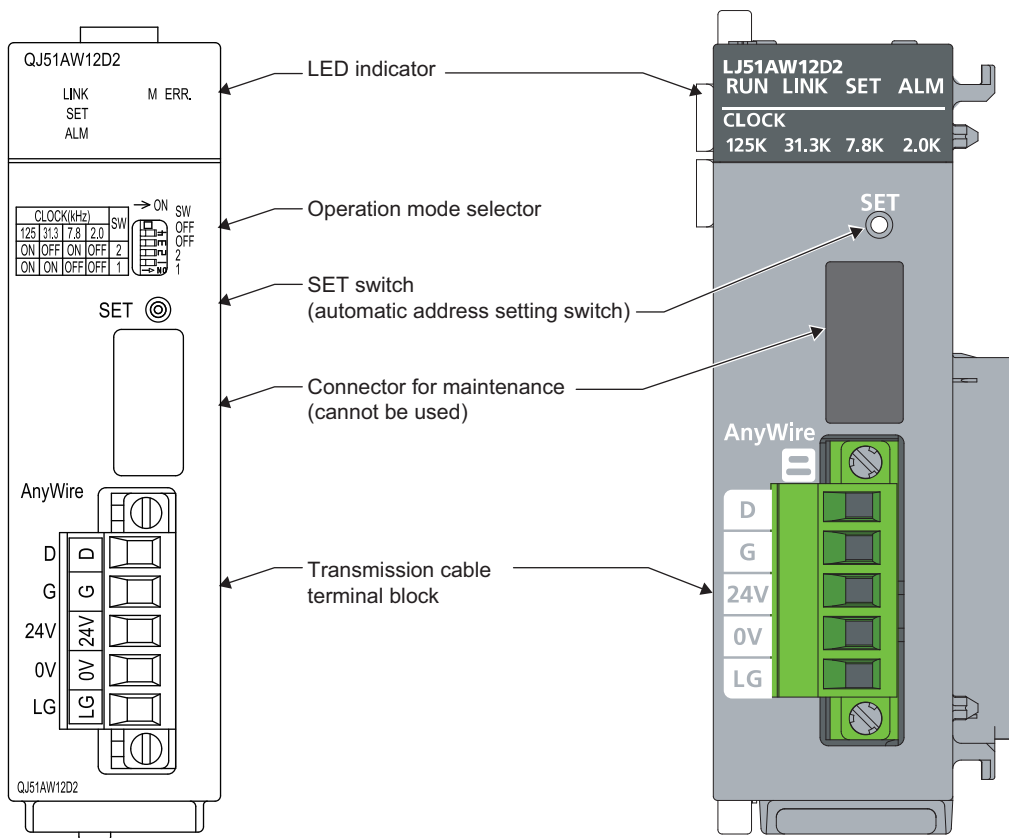

For details on each part, refer to the following.

- LED indicator: [Page 55, CHAPTER 6](#)
- Operation mode selector: [Page 29, Section 3.1](#)
- SET switch: [Page 53, Section 5.1](#)
- Transmission cable terminal block: [Page 57, CHAPTER 7](#)

## 2.6 Module Mounting

---

For precautions on the installation environment and the installation position of the modules, refer to the following.

- User's Manual (Hardware Design, Maintenance and Inspection) for the CPU module used
- MELSEC-L CC-Link IE Field Network Head Module User's Manual

## 2.7 Checking Function Version and Serial Number

The serial number and function version of the master module can be checked on the rating plate and the front of the module.

### (1) Checking on the rating plate

The rating plate is located on the side of the master module.

- QJ51AW12D2

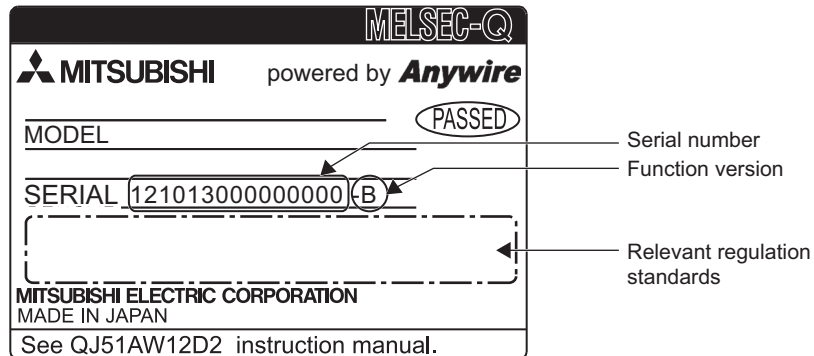

### (2) Checking on the front (at the bottom) of the module

The serial number on the rating plate is printed on the front (at the bottom) of the module.

- QJ51AW12D2

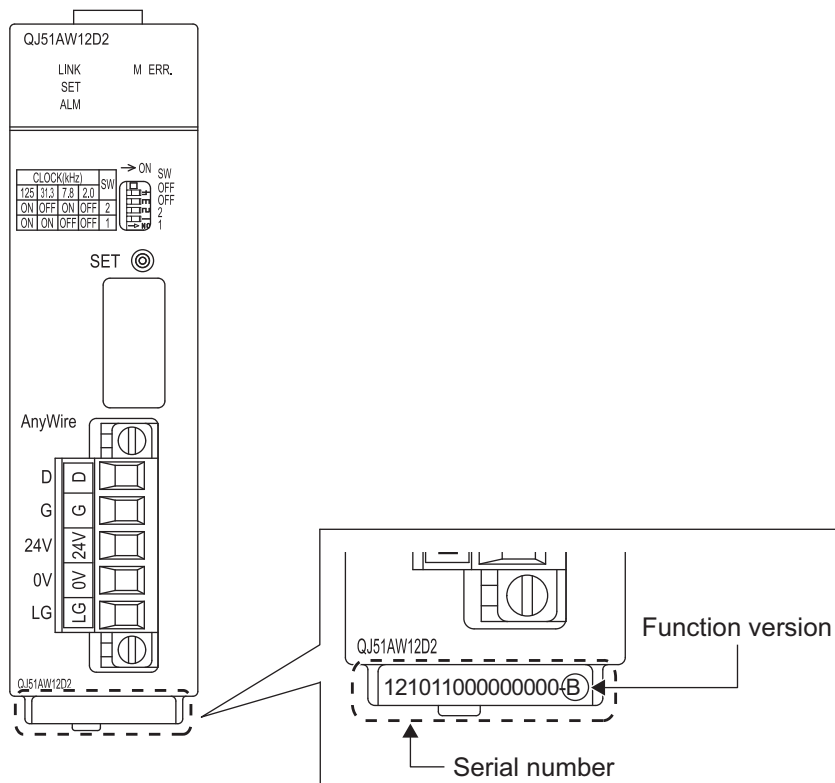

# CHAPTER 3 OPERATION MODE

Connect the slave module for the AnyWire DB A20.

## 3.1 QJ51AW12D2

### 3.1.1 Transmission speed setting

Select the settings such as the transmission distance using the operation mode selector (4-gang DIP switch).

- SW-1, 2 ... Set the transmission distance using a combination of ON/OFF for 1 and 2.
- SW-3 ... System reserve (Set the switch to OFF. Using the module with this switch set to ON may cause malfunction.)
- SW-4 ... System reserve (Set the switch to OFF. Using the module with this switch set to ON may cause malfunction.)

Switch		Specifications
1	2	
OFF	OFF	2kHz 3km
OFF	ON	7.8kHz 1km
ON	OFF	31.3kHz 200m
ON	ON	125kHz 50m

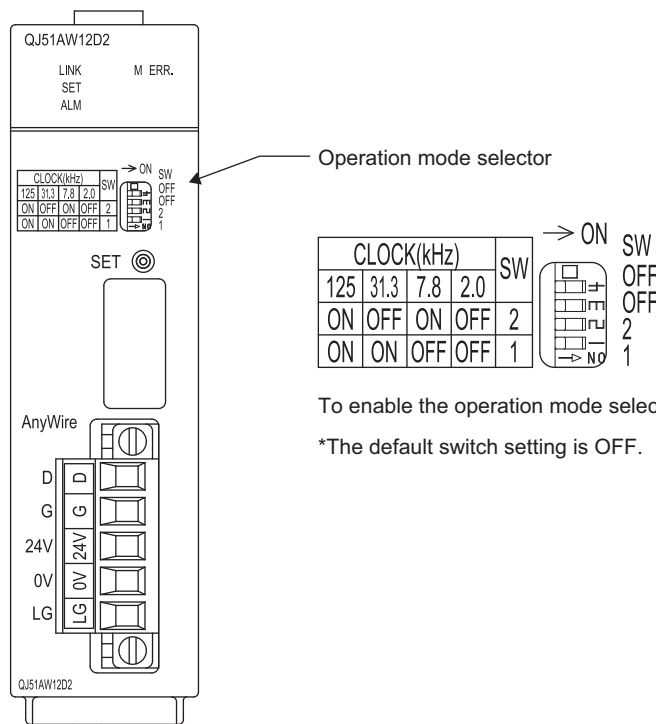

**Point!**

---

- Switch off the power supply before setting the operation mode.
  - Set the operation mode according to the transmission specifications being used.
  - If the transmission specifications of the QJ51AW12D2 do not match those of the connected slave module, transmission cannot be performed correctly, resulting in malfunction.
  - The operation mode selector is recessed from the front surface. When setting the switch, use a precision driver and be careful not to damage any of the internal boards.
-



## 3.1.2 Setting of the number of transmission points, double check mode, and waveform output method

Set the number of transmission points, double check mode, and waveform output method using "Switch 1", "Switch 3", and "Switch 4" of "Switch setting for I/O and intelligent function module".

Double-click the "PLC Parameter" in the Project window of the programming tool, and perform the following operations.

- Click the "I/O Assignment" tab.
- Click the "Switch Setting" button.
- Open the "Switch Setting for I/O and Intelligent Function Module" window.
- Set a value to "Switch 1", "Switch 3", and "Switch 4".

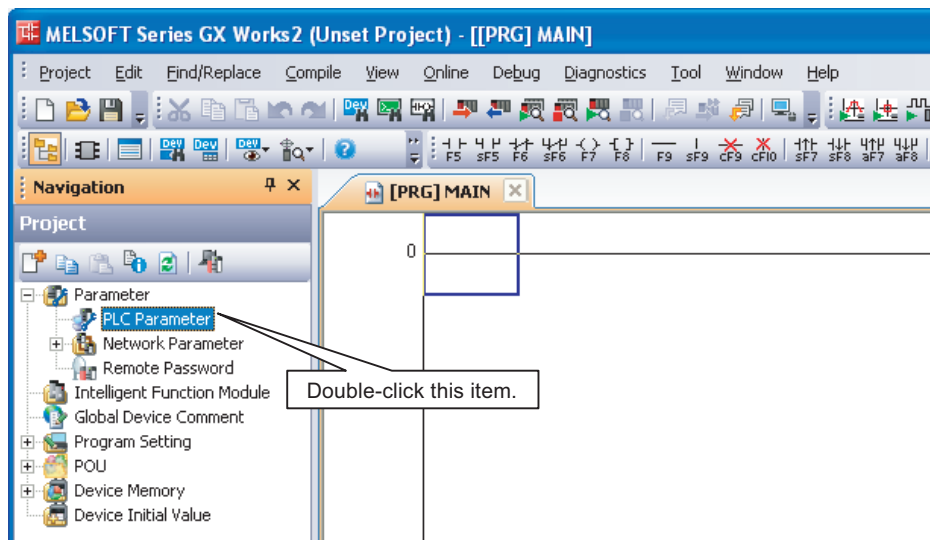

"Q Parameter Setting" window

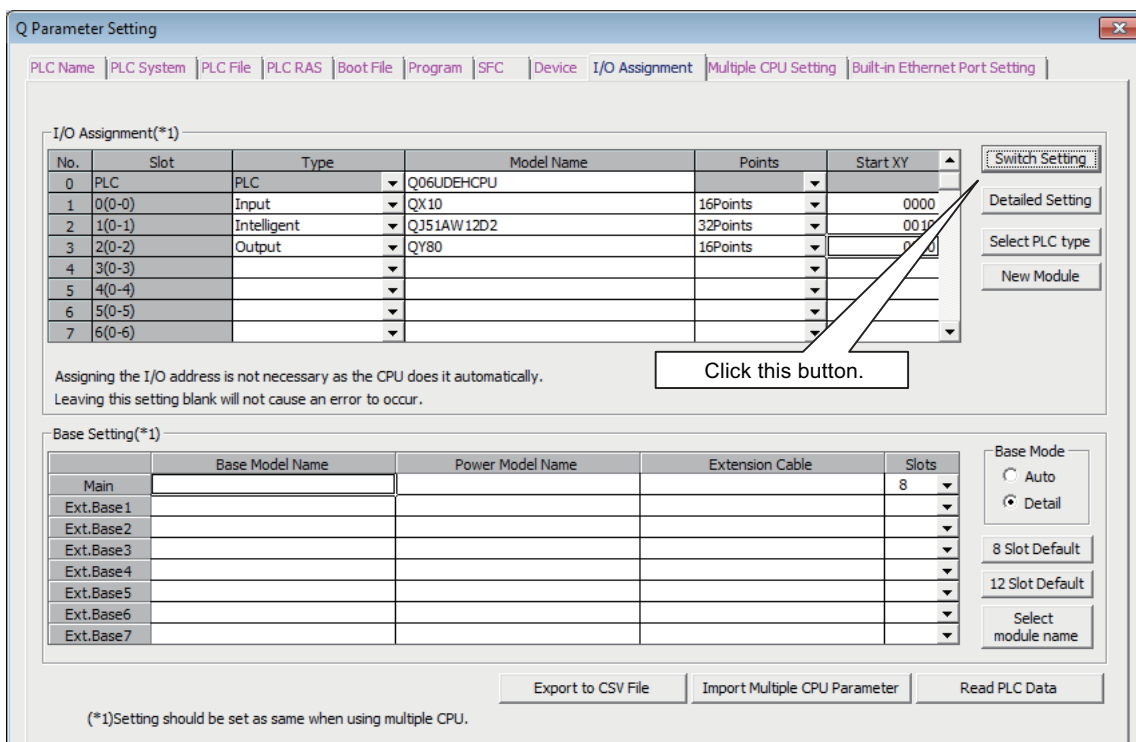

"Switch Setting for I/O and Intelligent Function Module" window

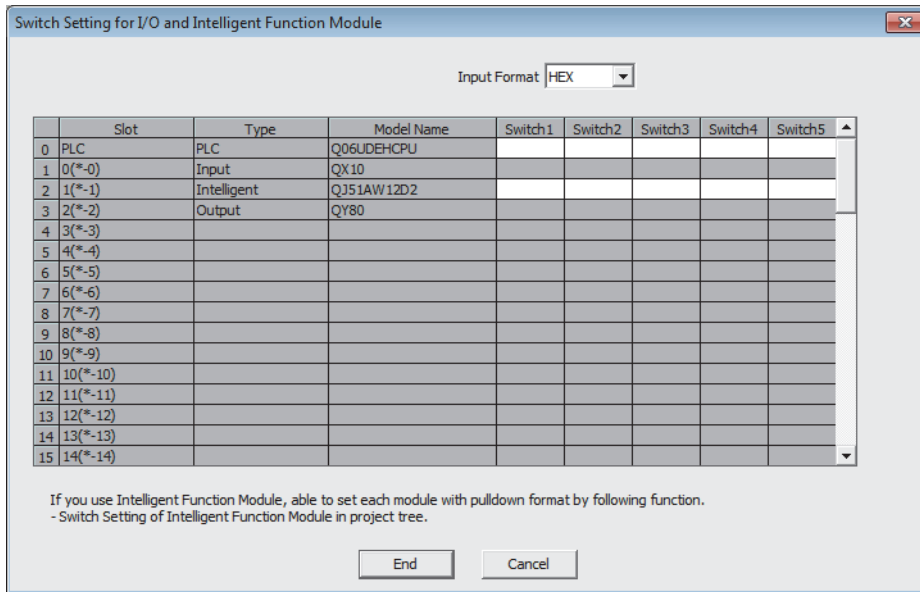

Set "Switch 1", "Switch 3", and "Switch 4" as follows.

- "Switch 1": Setting of the number of transmission points (☞ Page 33, Section 3.1.2 (1))
- "Switch 3": Double check mode setting (☞ Page 34, Section 3.1.2 (2))
- Switch 4: Waveform output method setting (☞ Page 36, Section 3.1.2 (3))

**Point**

- Be sure to set "Switch 1", "Switch 3", and "Switch 4". Furthermore, set the correct and suitable value for the slot position of the QJ51AW12D2. If the settings are not configured, or if the setting position or the switch selection value is incorrect, AnyWire DB A20 transmission does not operate normally.
- If the switch settings are changed using the programming tool, write the parameters and supply the power again or reset the system. Without these operations, switch settings are not configured.

### (1) Setting of the number of transmission points

Set the number of transmission points using "Switch 1" of "Switch setting for I/O and intelligent function module".

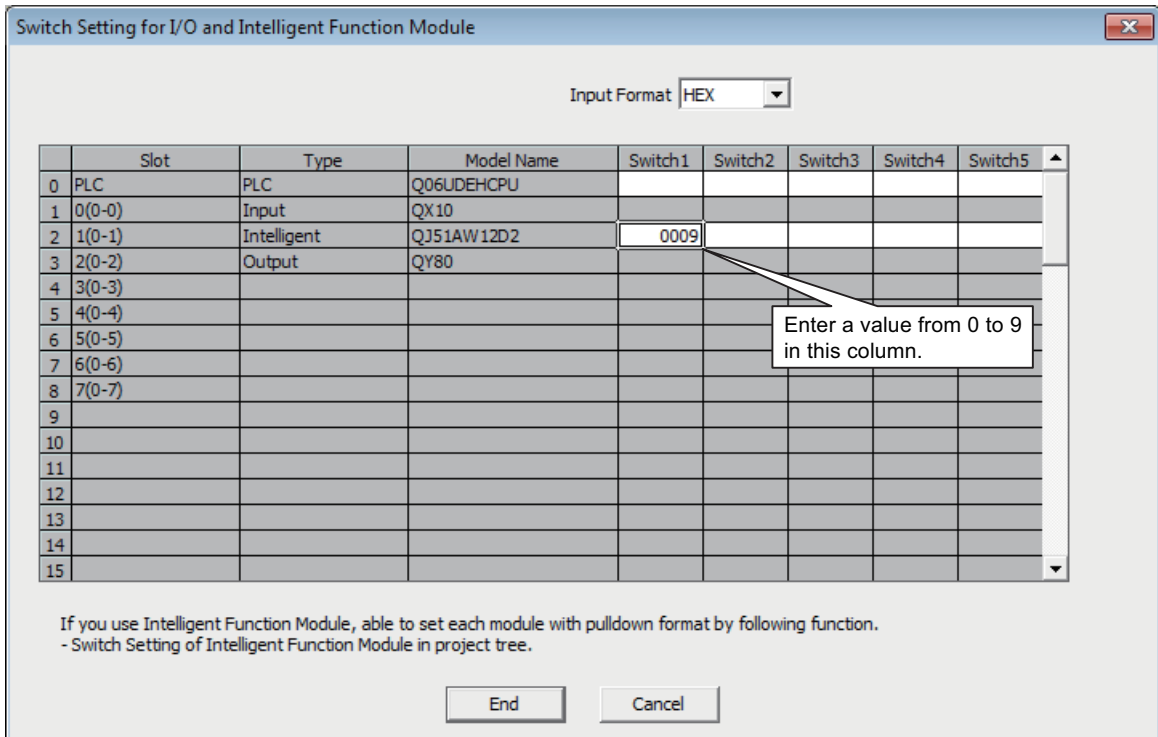

■ Correspondence between the value from 0 to 9 set for "Switch 1" and the number of connected I/O points

Number of connected I/O points		"Switch 1"*1
Input	Output	
512	512	0
448	448	1
384	384	2
320	320	3
256	256	4
192	192	5
128	128	6
64	64	7
32	32	8
1024	1024	9*2

\*1 The value other than 0 to 9 is reserved by the system. Do not change the settings.

\*2 Used when required in special situations.

Transmission also can be made for normal use. However, the address after the "Maximum address setting-Number of self occupied points" of the slave module for AnyWire DB A20 becomes unassigned, and the transmission cycle time becomes slower.

**Ex** For 32-Point Remote I/O Module

- Maximum address setting: 510
- Number of self occupied points: 32 points

According to the details above, up to 510 to 541 points are used as the maximum address that is occupied by the remote I/O module.

Addresses of 541 to 1023 points become unassigned, and cannot be assigned.

3.1 QJ51AW12D2  
3.1.2 Setting of the number of transmission points; double check mode; and waveform output method

## (2) Double check mode setting

Set the double check mode using "Switch 3" of "Switch setting for I/O and intelligent function module".  
The QJ51AW12D2 with a serial number where the sixth digit is "6" or later can be set.

	Slot	Type	Model Name	Switch1	Switch2	Switch3	Switch4	Switch5
0	PLC	PLC	Q06UDEHCPU					
1	0(0-0)	Input	QX10					
2	1(0-1)	Intelligent	QJ51AW12D2	0009		003F		
3	2(0-2)	Output	QY80					
4	3(0-3)							
5	4(0-4)							
6	5(0-5)							
7	6(0-6)							
8	7(0-7)							
9								
10								
11								
12								
13								
14								
15								

If you use Intelligent Function Module, able to set each module with pull-down format by following function.  
- Switch Setting of Intelligent Function Module in project tree.

End Cancel

### ■ Correspondence between the value from 0 to 40 set for "Switch 3" and the double check

Double check	"Switch 3"*1
Bit data at all points are double-checked.	0
Word data (16 bits) of the first word are double-checked. At the remaining points, bit data are double-checked.	1
Word data (16 bits) of the first two words are double-checked. At the remaining points, bit data are double-checked.	2
Word data (16 bits) of the first three words are double-checked. At the remaining points, bit data are double-checked.	3
⋮	⋮
Word data (16 bits) of the first 63 words are double-checked. At the remaining points, bit data are double-checked.	3F
Word data (16 bits) at all points are double-checked.	40

\*1 The value other than 0 to 40 is reserved by the system. Do not change the settings.

The double check is an error control system of the AnyWire DB A20 where the data transmitted in the last cycle are checked with those in the current cycle and when they are verified to be identical, they are handled as valid data.

#### Double check of bit data

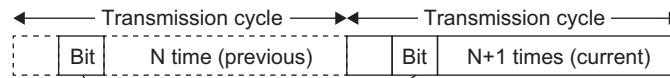

If the same bit data is verified twice successively, input and output are performed as a valid data.

#### Double check of word data

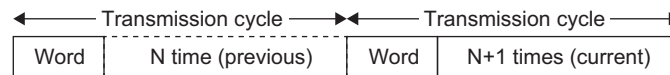

If the same word data is verified twice successively, input and output are performed as a valid data.

### Point

- Using the "Switch 3" setting, data (bit or word) to be double-checked within the frame can be selected from the head area of the transmission frame.
- Digital I/O slave modules are suitable for bit double check, and analog I/O slave modules are suitable for word double check.

### (3) Waveform output method setting

Set the waveform output method using "Switch 4" of "Switch setting for I/O and intelligent function module". The QJ51AW12D2 with a serial number where the sixth digit is "6" or later can be set.

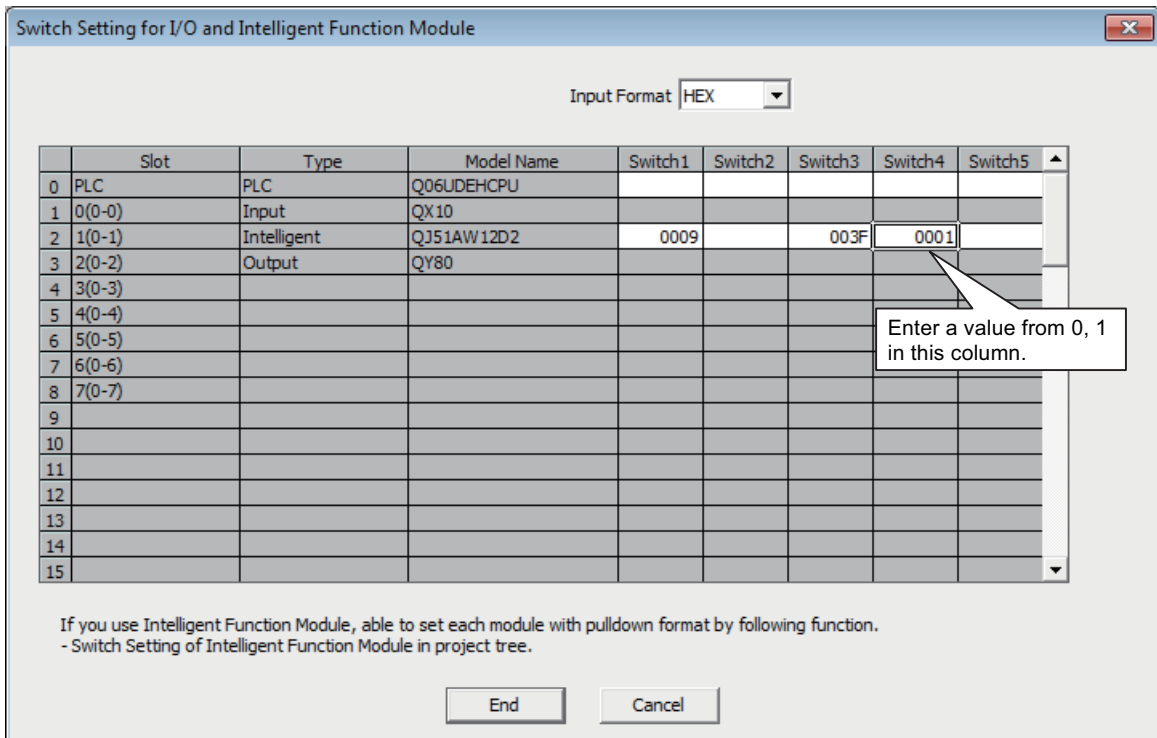

■ Correspondence between the value from 0 to 1 set for "Switch 4" and the waveform output method

Waveform output method	"Switch 4"*1
When Module READY (Xn0) turns on, the transmission waveform is output.	0
When Module READY (Xn0) and Transmission waveform output command (Yn2) turn on, the transmission waveform is output.	1

\*1 The value other than 0 and 1 is reserved by the system. Do not change the settings.

# 3.2 LJ51AW12D2

Set the operation mode using "Switch setting for I/O and intelligent function module". Double-click "PLC Parameter" in the Project window of the programming tool, and perform the following operations.

- Click the "I/O Assignment" tab.
- Click the "Switch Setting" button.
- Open the "Switch Setting for I/O and Intelligent Function Module" window.
- Set a value to "Switch 1" to "Switch 4".

3

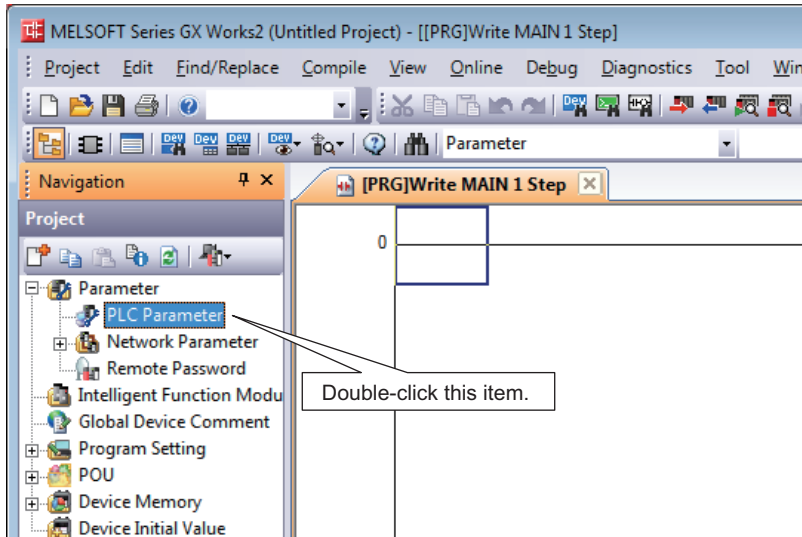

"L Parameter Setting" window

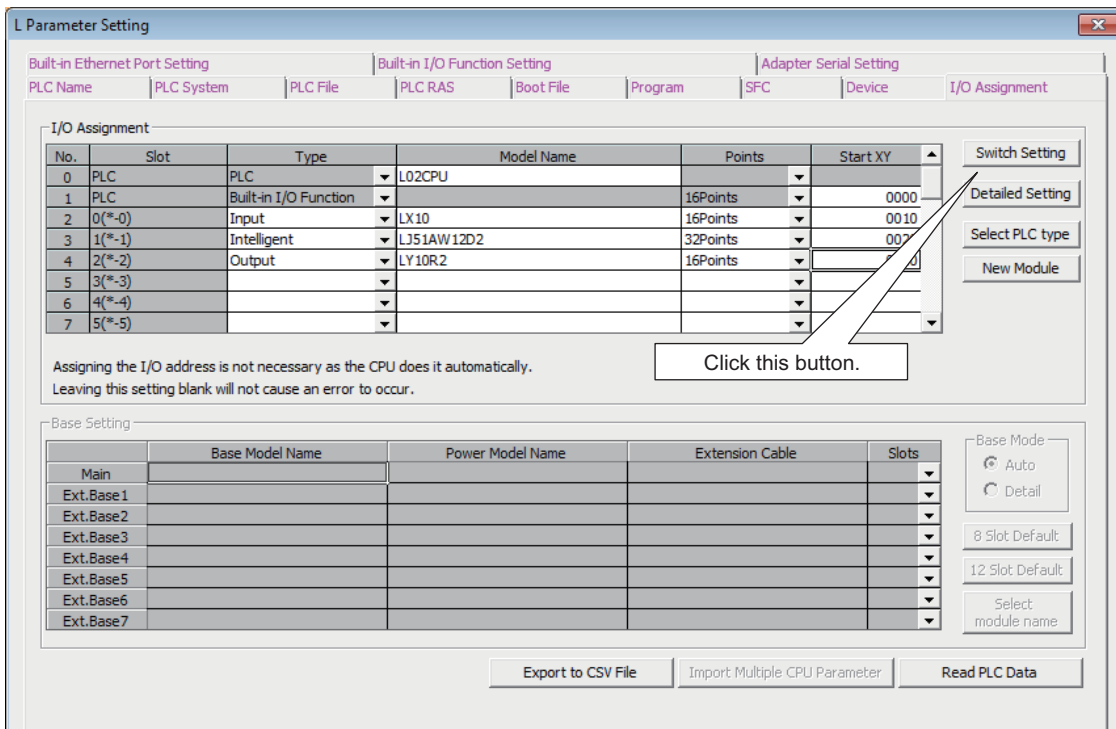

3.2 LJ51AW12D2

"Switch Setting for I/O and Intelligent Function Module" window

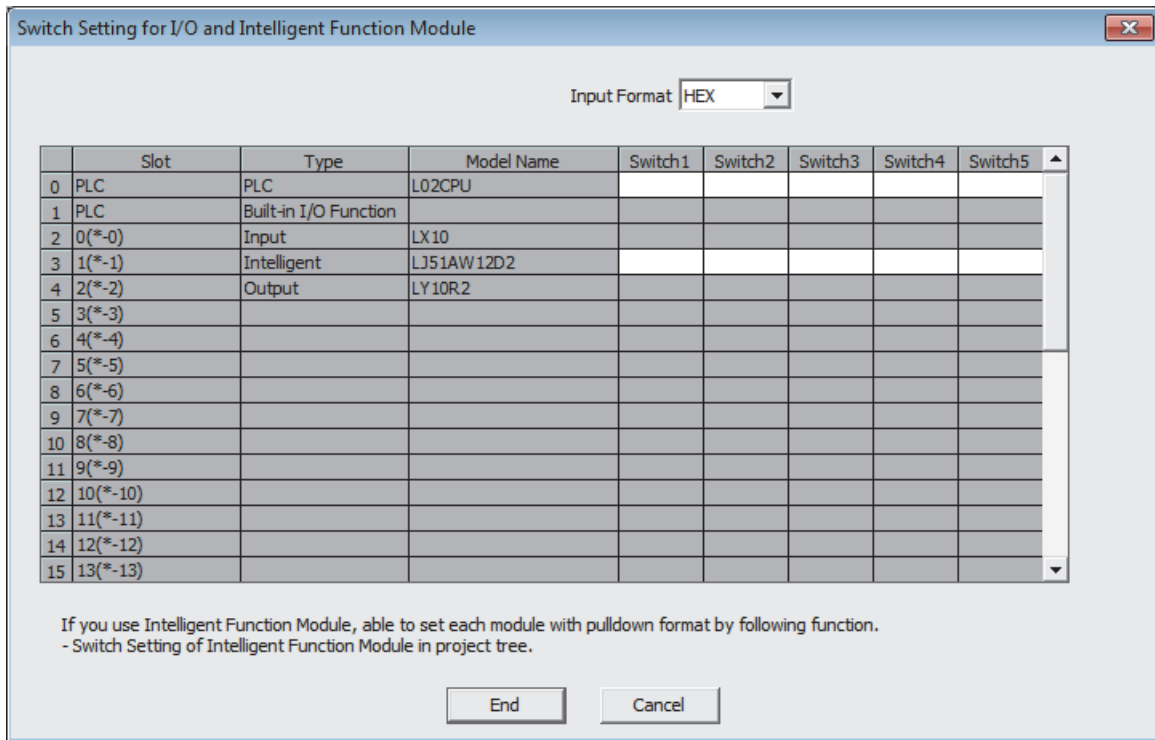

Set "Switch 1" to "Switch 4" as follows.

- "Switch 1": Setting of the number of transmission points ( Page 39, Section 3.2.1)
- "Switch 2": Transmission speed setting ( Page 40, Section 3.2.2)
- "Switch 3": Double check mode setting ( Page 41, Section 3.2.3)
- Switch 4: Waveform output method setting ( Page 43, Section 3.2.4)

**Point**

- Be sure to set "Switch 1" to "Switch 4". Furthermore, set the correct and suitable value for the slot position of the LJ51AW12D2. If the settings are not configured, or if the setting position or the switch selection value is incorrect, the AnyWire DB A20 transmission does not operate normally.
- If the switch settings are changed using the programming tool, write the parameters and supply the power again or reset the system. Without these operations, switch settings are not configured.



## 3.2.1 Setting of the number of transmission points

Set the number of transmission points using "Switch 1" of "Switch setting for I/O and intelligent function module".

Slot	Type	Model Name	Switch1	Switch2	Switch3	Switch4	Switch5
0	PLC	L02CPU					
1	PLC	Built-in I/O Function					
2	0(*-0)	Input					
3	1(*-1)	Intelligent	0009				
4	2(*-2)	Output					
5	3(*-3)						
6	4(*-4)						
7	5(*-5)						
8	6(*-6)						
9	7(*-7)						
10	8(*-8)						
11	9(*-9)						
12	10(*-10)						
13	11(*-11)						
14	12(*-12)						
15	13(*-13)						

If you use Intelligent Function Module, able to set each module with pulldown format by following function.  
- Switch Setting of Intelligent Function Module in project tree.

End Cancel

- Correspondence between the value from 0 to 9 set for "Switch 1" and the number of connected I/O points

Number of connected I/O points		"Switch 1"*1
Input	Output	
512	512	0
448	448	1
384	384	2
320	320	3
256	256	4
192	192	5
128	128	6
64	64	7
32	32	8
1024	1024	9*2

\*1 The value other than 0 to 9 is reserved by the system. Do not change the settings.

\*2 Used when required in special situations.

Transmission also can be made for normal use. However, the address after the "Maximum address setting-Number of self occupied points" of the slave module for AnyWire DB A20 becomes unassigned, and the transmission cycle time becomes slower.

### For 32-Point Remote I/O Module

- Maximum set address: 510
- Number of self-occupied points: 32 points

According to the details above, up to 510 to 541 points are used as the maximum address that is occupied by the remote I/O module.

Addresses of 541 to 1023 points become unassigned, and cannot be assigned.

## 3.2.2 Transmission speed setting

Set the transmission speed using "Switch 2" of "Switch setting for I/O and intelligent function module".

Slot	Type	Model Name	Switch1	Switch2	Switch3	Switch4	Switch5
0	PLC	L02CPU					
1	PLC	Built-in I/O Function					
2	0(*-0)	Input					
3	1(*-1)	Intelligent		0002			
4	2(*-2)	Output	0009				
5	3(*-3)						
6	4(*-4)						
7	5(*-5)						
8	6(*-6)						
9	7(*-7)						
10	8(*-8)						
11	9(*-9)						
12	10(*-10)						
13	11(*-11)						
14	12(*-12)						
15	13(*-13)						

If you use Intelligent Function Module, able to set each module with pulldown format by following function.  
- Switch Setting of Intelligent Function Module in project tree.

End Cancel

- Correspondence between the value from 0 to 3 set for "Switch 2" and the transmission speed

Transmission speed (transmission distance)	"Switch 2"*1
2kHz 3km	0
7.8kHz 1km	1
31.3kHz 200m	2
125kHz 50m	3

\*1 The value other than 0 to 3 is reserved by the system. Do not change the settings.

## 3.2.3 Double check mode setting

Set the double check mode using "Switch 3" of "Switch setting for I/O and intelligent function module".

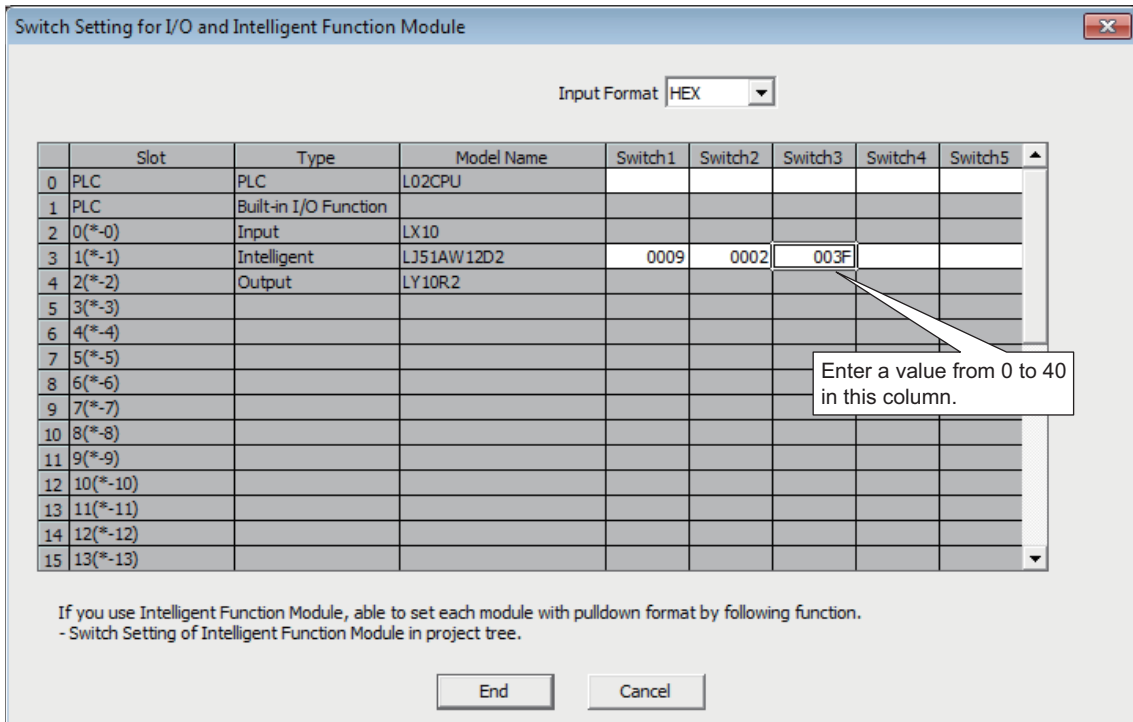

- Correspondence between the value from 0 to 40 set for "Switch 3" and the double check

Double check	"Switch 3"*1
Bit data at all points are double-checked.	0
Word data (16 bits) of the first word are double-checked. At the remaining points, bit data are double-checked.	1
Word data (16 bits) of the first two words are double-checked. At the remaining points, bit data are double-checked.	2
Word data (16 bits) of the first three words are double-checked. At the remaining points, bit data are double-checked.	3
⋮	⋮
Word data (16 bits) of the first 63 words are double-checked. At the remaining points, bit data are double-checked.	3F
Word data (16 bits) at all points are double-checked.	40

\*1 The value other than 0 to 40 is reserved by the system. Do not change the settings.

The double check is an error control system of the AnyWire DB A20 where the data transmitted in the last cycle are checked with those in the current cycle and when they are verified to be identical, they are handled as valid data.

Double check of bit data

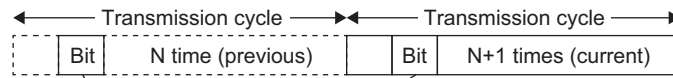

If the same bit data is verified twice successively, input and output are performed as a valid data.

Double check of word data

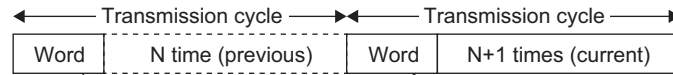

If the same word data is verified twice successively, input and output are performed as a valid data.

**Point** 

- Using the "Switch 3" setting, data (bit or word) to be double-checked within the frame can be selected from the head area of the transmission frame.
- Digital I/O slave modules are suitable for bit double check, and analog I/O slave modules are suitable for word double check.

## 3.2.4 Waveform output method setting

Set the waveform output method using "Switch 4" of "Switch setting for I/O and intelligent function module".

Switch Setting for I/O and Intelligent Function Module

Input Format: HEX

Slot	Type	Model Name	Switch1	Switch2	Switch3	Switch4	Switch5
0	PLC	L02CPU					
1	PLC	Built-in I/O Function					
2	0(*-0)	Input					
3	1(*-1)	Intelligent				0001	
4	2(*-2)	Output	0009	0002	003F		
5	3(*-3)						
6	4(*-4)						
7	5(*-5)						
8	6(*-6)						
9	7(*-7)						
10	8(*-8)						
11	9(*-9)						
12	10(*-10)						
13	11(*-11)						
14	12(*-12)						
15	13(*-13)						

If you use Intelligent Function Module, able to set each module with pulldown format by following function.  
- Switch Setting of Intelligent Function Module in project tree.

End Cancel

- Correspondence between the value from 0 to 1 set for "Switch 4" and the waveform output method

Waveform output method	"Switch 4"*1
When Module READY (Xn0) turns on, the transmission waveform is output.	0
When Module READY (Xn0) and Transmission waveform output command (Yn2) turn on, the transmission waveform is output.	1

\*1 The value other than 0 and 1 is reserved by the system. Do not change the settings.

# CHAPTER 4 PROGRAMMING

This chapter describes programs of the master module.

When applying the program examples introduced in this chapter to the actual system, ensure the applicability and confirm that it does not cause system control problems.

## 4.1 I/O Signals with CPU Module

The master module is an intelligent function module. Thirty-two input points and 32 output points are used for the data communication with the CPU module.

System status information is stored in this area.

The "buffer memory area" is used to input/output the signal to/from the remote I/O module.

### 4.1.1 I/O signal list

The "n" in the table below is the start I/O number of the master module which is determined according to the installation position and modules installed before the master module.

**Ex** If the start I/O number of the master module is "X/Y10"

Xn0 to X(n+1)F → X10 to X2F

Yn0 to Y(n+1)F → Y10 to Y2F

Input number	Signal name	Output number	Signal name
Xn0	Module READY	Yn0	Disconnection flag reset command output
Xn1	Short between D and G terminals	Yn1	Automatic address detection command output
Xn2	Short between D and 24 V terminals	Yn2 <sup>*4</sup>	Transmission waveform output command
Xn3	24 V not applied	Yn3 ⋮ YnF	Use prohibited
Xn4	D/G line disconnection		
Xn5 to Xn7	Use prohibited		
Xn8 to XnB <sup>*1</sup>	"Switch Setting for I/O and Intelligent Function Module" Switch 1 setting value <sup>*2</sup>		
XnC to XnF	Use prohibited	Y(n+1)0 to Y(n+1)F	Use prohibited
X(n+1)0 to X(n+1)3	Use prohibited		
X(n+1)4 <sup>*3</sup>	Automatic address detection flag		
X(n+1)5 to X(n+1)F	Use prohibited		

\*1 Use prohibited for the LJ51AW12D2.

\*2 When 8 is set for "Switch 1", the settings are as follows.

Xn8: OFF, Xn9: OFF, XnA: OFF, XnB: ON

\*3 Use prohibited for the QJ51AW12D2.

\*4 The QJ51AW12D2 with a serial number where the sixth digit is "6" or later can be used.

## 4.1.2 Details of the input signal

The input signal "Xn0" is the "Module READY" flag, and it turns on while the master module is operating normally. (It does not turn OFF with Xn1 to Xn4 errors.)

If the input signal is "Xn1 to Xn4", an "Error Flag" that shows the condition of the AnyWire DB A20 transmission cable turns on.

If normal, the corresponding input signal switches to "OFF", and if an error occurs, it switches to "ON".

Xn1 to Xn3 flags turn "OFF" when the error is removed and then maintain the OFF status.

Xn4 maintains the ON status even when the error is removed.

Xn4 turns "OFF" by resetting the power or outputting the signal to Yn0. (☞ Page 45, Section 4.1.3)

The ON/OFF status is also indicated depending on whether the "ALM" LED is ON or how the "ALM" LED flashes.

Input signal No.	Description	Normal	Error
Xn0	Module READY (Turns OFF when a watchdog timer error occurs)	ON	OFF
Xn1	Short between D and G terminals	OFF	ON
Xn2	Short between D and 24 V terminals	OFF	ON
Xn3	24VDC is not being supplied to the master module or the voltage is low.	OFF	ON
Xn4	D/G line disconnection, a slave module error, or power is not being supplied	OFF	ON

For Xn8 to XnB, enter the value set for switch 1 of the "Switch setting for I/O and Intelligent Function Module". Xn8 to XnB are used to check the settings.

X(n+1)4 turns on when the automatic address detection function is being executed. (☞ Page 53, Section 5.1)

## 4.1.3 Details of the output signal

### (1) Disconnection flag reset command output

When the output signal Yn0 is turned off and on, provided that the disconnection error has been removed, the error address information can be cleared by turning off D/G terminal disconnection (Xn4) and resetting the number of error addresses to "0".

If the error has not been removed, the error flag, the number of the error addresses, and error address are set. Abnormal address information can also be cleared by supplying the power again.

### (2) Automatic address detection command output

Turning the output signal Yn1 from OFF to ON starts the automatic detection of the address. (☞ Page 52, CHAPTER 5)

(The "Automatic address detection" function can be also operated using the SET switch.)

### (3) Transmission waveform output command

This signal is valid when "Switch 4" of "Switch setting for I/O and intelligent function module" is set to "1".

When the output signal Yn2 is turned off and on, the transmission waveform of the AnyWire DB A20 is output.

## 4.2 Buffer Memory Area

This area is for data communication between the master module and CPU module.

Buffer memory address	Description
100 <sub>H</sub> to 13F <sub>H</sub> <sup>*1</sup>	Input (1024 points): The least significant bit of 100 <sub>H</sub> is the 0th data, and the most significant bit of 13F <sub>H</sub> is the 1023rd data.
1100 <sub>H</sub> to 113F <sub>H</sub> <sup>*1</sup>	Output (1024 points): The least significant bit of 1100 <sub>H</sub> is the 0th data, and the most significant bit of 113F <sub>H</sub> is the 1023rd data.
2000 <sub>H</sub>	Number of error IDs (1 word)
2001 <sub>H</sub> to 2080 <sub>H</sub>	Error ID information
2400 <sub>H</sub> <sup>*2</sup>	Number of connection IDs (1 word)
2401 <sub>H</sub> to 2480 <sub>H</sub> <sup>*2</sup>	Connection ID information
2810 <sub>H</sub> <sup>*2</sup>	Latest error code storage area
2811 <sub>H</sub> <sup>*2</sup>	Latest error ID storage area

\*1 The buffer memory address occupies a 64-word sized area, irrespective of the number of I/O points set for "Switch 1" setting on Page 31, Section 3.1.2.

\*2 The QJ51AW12D2 with a serial number where the sixth digit is "6" or later can be used.

**Ex.** Correspondence between the buffer memory address and AnyWire DB A20 input address

Buffer memory address	Bit No.															
	15	14	13	12	11	10	9	8	7	6	5	4	3	2	1	0
100 <sub>H</sub>	15	14	13	12	11	10	9	8	7	6	5	4	3	2	1	0
101 <sub>H</sub>	31	30	29	28	27	26	25	24	23	22	21	20	19	18	17	16

|  
|  
|

|  
|  
|

AnyWire input address: 0



## 4.2.1 I/O area

The slave module requires "Address setting" which specifies the start number assigned in the transmission frame. The settings are configured in 2-point unit. The addresses of both an input slave module (e.g. input remote I/O module) and an output slave module (e.g. output remote I/O module) start from "0", and the area later than that number is occupied corresponding to the number of module points.

**Ex.** Assignment of two 8-point input remote I/O modules

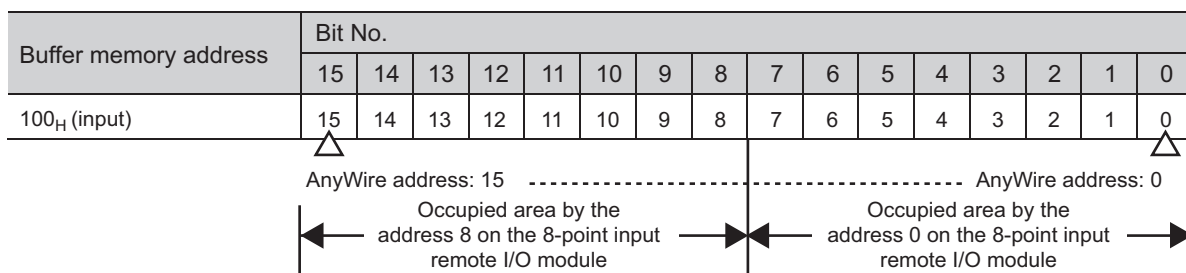

4

4.2 Buffer Memory Area  
4.2.1 I/O area

## 4.2.2 Number of error addresses

---

The number of error IDs (addresses) is entered in 2000<sub>H</sub>. (☞ Page 52, CHAPTER 5)

Any value from 0 to 128 is entered.

## 4.2.3 Value of error addresses

---

If a disconnection or a slave module error is occurred, the error address is written to 2001<sub>H</sub> to 2080<sub>H</sub> in the order from the lowest address up to 128 addresses.

This value is maintained until the disconnection error is reset or until the power is turned off.

Buffer memory address	Description
2001 <sub>H</sub>	Error address 1
2002 <sub>H</sub>	Error address 2
2003 <sub>H</sub>	Error address 3
⋮	⋮
⋮	⋮
207F <sub>H</sub>	Error address 127
2080 <sub>H</sub>	Error address 128

The detected error address is classified and displayed in the memory and on the monitor according to the table below.

Hexadecimal display address	Description
000 <sub>H</sub> to 1FF <sub>H</sub>	Slave module output address
200 <sub>H</sub> to 3FF <sub>H</sub>	Slave module input address

The lower 2 digits indicate the address set for the slave module.

The uppermost digit indicates the type of the slave module.

## 4.2.4 Number of connection addresses

The number of connection IDs (addresses) is entered in 2400<sub>H</sub>. (☞ Page 52, CHAPTER 5)

Any value from 0 to 128 is entered.

## 4.2.5 Value of connection addresses

Up to 128 addresses of all the slave modules connected to the master module are written to 2401<sub>H</sub> to 2480<sub>H</sub> in the order from the lowest address.

These values are maintained until the power is turned off.

Buffer memory address	Description
2401 <sub>H</sub>	Connection addresses 1
2402 <sub>H</sub>	Connection addresses 2
2403 <sub>H</sub>	Connection addresses 3
⋮	⋮
⋮	⋮
247F <sub>H</sub>	Connection addresses 127
2480 <sub>H</sub>	Connection addresses 128

The detected connection addresses are classified and displayed in the memory and on the monitor according to the table below.

Hexadecimal display address	Description
000 <sub>H</sub> to 1FF <sub>H</sub>	Slave module output address
200 <sub>H</sub> to 3FF <sub>H</sub>	Slave module input address

The lower 2 digits indicate the address set for the slave module.

The uppermost digit indicates the type of the slave module.

## 4.2.6 Latest error code storage area, latest error ID storage area

The latest error code is stored in 2810<sub>H</sub>.

The latest error code is maintained even after the error is cleared.

The ID (address) of the error code stored in 2810<sub>H</sub> is stored in 2811<sub>H</sub>.

However, for Transmission cable power supply voltage drop error (00C8<sub>H</sub>), D/G short error (00C9<sub>H</sub>), D/24V short error (00CB<sub>H</sub>), Master module hardware error (0064<sub>H</sub> to 0067<sub>H</sub>), and CPU module stop error (0068<sub>H</sub>), 0X0FFF<sub>H</sub> is entered in 2811<sub>H</sub>.

# 4.3 Program Example

The configuration of the programmable controller is as shown below.

**Ex** QJ51AW12D2

I/O address		X0 to XF	X10 to X2F	Y10 to Y2F
Power supply Q62P	CPU Q06UDHCPU	16-point input module	QJ51 AW12D2	16-point output module
Vacant				

- Used device

Device No.	Application
SM400	Always ON
X10	Module READY
X11	D/G terminal short
X12	D/24V terminal short
X13	24V not applied
X14	D/G line disconnection
Y10	Disconnection flag reset command output
Y11	Automatic address detection command output
M1	Disconnection flag reset command input
M2	Access start flag
M3	Automatic address detection command input
M10	Display of D/G terminal short
M11	Display of D/24V terminal short
M12	Display of 24V not applied
M13	Display of D/G line disconnection
T1	Disconnection flag output ON time (500 ms)

- Program <Disconnection flag clear>



Input is output by the FROM instruction, and output is output by the TO instruction.  
 A user program is added between the FROM and TO instructions.

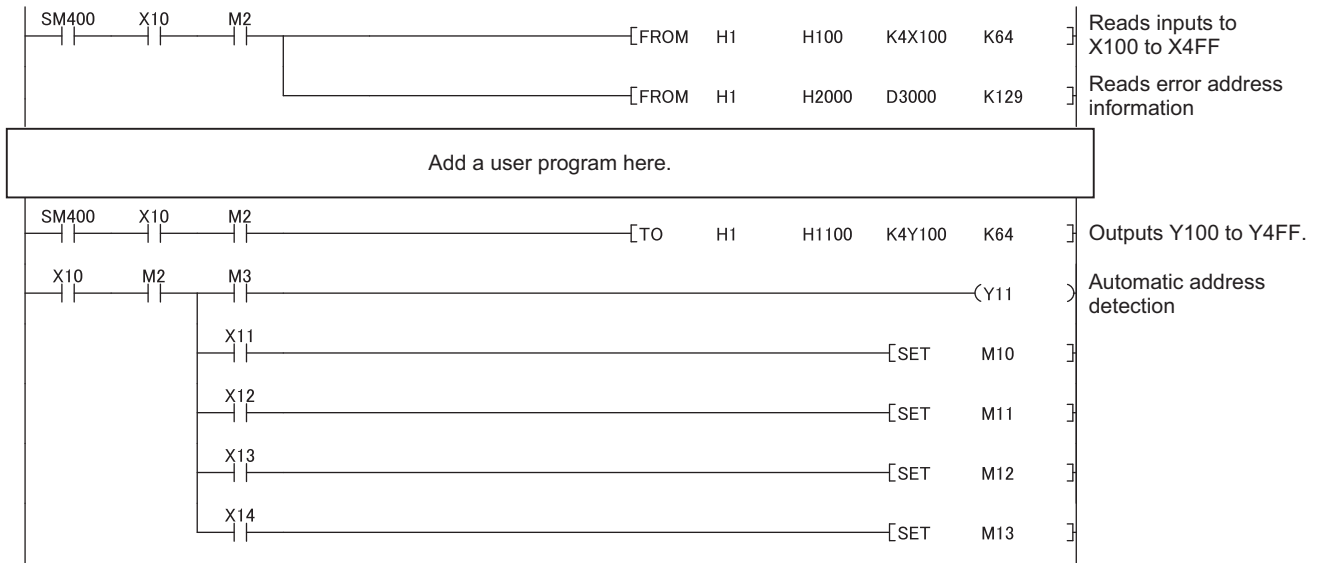

4

The correspondence between each signal and the device in the program above is as shown below.

Signal type	Corresponding device
Input (1024 points)	X100 to X4FF
Output (1024 points)	Y100 to Y4FF
Error address information	D3000 to D3128

# CHAPTER 5 MONITORING FUNCTION

---

The AnyWire DB A20 slave module has the specific ID (address). When the master module sends the ID (address), disconnection and existence of slave modules are detected by receiving a reply from the slave module having the corresponding ID (address).

The master module uses the automatic address detection operation to store the addresses of the currently connected slave modules in the EEPROM.

This information is stored even when the power is turned off.

The master module sends the registered addresses in order. If the corresponding slave module does not reply, the "ALM" LED displays that a disconnection has occurred. Then an error flag is returned to the memory area on the host side.

Furthermore, this slave module address can be checked.

## 5.1 Automatic Address Detection

Automatic address detection is a function to store the ID (address) of the connected slave module in the EEPROM of the master module.

In the initial system startup, the ID is not yet registered in the module. Therefore, when the power is on, the "ALM" LED and the "D/G line disconnection" flag are turned on. (☞ Page 44, CHAPTER 4, Page 55, CHAPTER 6) I/O data can be transmitted in this state. However, to use the disconnected branch line detection function, operate "automatic address detection" at this point.

Operate the automatic address detection in the following situations.

- When starting the system operation after confirming that all the slave modules connected to the master modules are operating normally
- When adding a slave module after starting the system operation
- When removing a slave module after starting the system operation
- When changing the address of a slave module after starting the system operation

### 5.1.1 Automatic address detection operation

Use the SET switch or Automatic address detection command output (Yn1) to operate the automatic address detection.

Using the SET switch

Procedure

- 1. Check that all of the slave modules are operating normally.**
- 2. Keep pressing the SET switch on the master module until the SET LED (green) turns on.**
- 3. When the "SET" LED turns on, flashes, and turns off, the ID (address) has been stored.**

Using Automatic address detection command output (Yn1)

Procedure

- 1. Check that all of the slave modules are operating normally.**
- 2. Turn Automatic address detection command output (Yn1) from OFF to ON. (For details on Automatic address detection command output (Yn1), refer to Page 44, CHAPTER 4.)**
- 3. When the "SET" LED turns on, flashes, and turns off, the ID (address) has been stored.**

#### **Point**

When an error such as a short occurs in AnyWire DB A20, when the power is turned on, or when the module is reset, the automatic address detection cannot be operated for approximately 5 seconds.

## 5.2 Monitoring Operation

---

Registered IDs (addresses) are sent in order. If the slave module does not reply, a disconnection is notified.

The "ALM" LED turns on and the input Xn4 turns on when a disconnection occurs.

This error information is maintained until the power is turned off or until Disconnection flag reset command output (Yn0) is turned on.

---

### *Point*

To reset the "ALM" LED lighting and D/G terminal disconnection (Xn4: ON) which are detected during operation, after removing the cause, reset the power supply of the master module or turn on Disconnection flag reset command output (Yn0).

The automatic address detection also clears the display and the flag. However, if an unresponding module exists, its ID (address) is not registered; therefore, it is not monitored.

---



# CHAPTER 6 LED DISPLAY

## 6.1 QJ51AW12D2

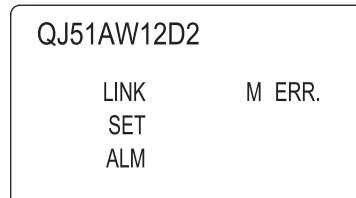

Name	Color	Meaning	
LINK	Green	Flashing	Module operating status
		Off	Module failure
SET	Green	On	During automatic address detection operation
		Flashing	During EEPROM write
		Off	During normal transmission
ALM	Red	On	AnyWire DB A20 D/G line disconnection, or no reply from the slave module
		Slow flashing <sup>*1</sup>	Short between D and G terminals, short between D and 24V terminals, or the equivalent status
		Fast flashing <sup>*2</sup>	24VDC is not being supplied, or the supply voltage is too low
		Off	During normal transmission
M ERR.	Red	On	Turns on when an error occurs in the QJ51AW12D2 or the programmable controller. In this case, all functions are stopped. The error LED for the applicable CPU flashes. (Excluding EEPROM errors)
		Off	Module normal

\*1 "Slow flashing": at approximately one-second intervals

\*2 "Fast flashing": at approximately 0.2-second intervals

For details on the display when M ERR. is on, see the table below.

No.	On/Off status				Main Causes
	M ERR.	ALM	LINK	SET	
1	●	●	●	●	Internal ROM error
2	●	●	●	○	Internal RAM error
3	●	*3	*3	●	EEPROM error
4	●	○	○	○	Module initialization error
5	●	○	●	○	Watchdog timer error
6	●	○	○	●	Programmable controller CPU error (ITWDT)
7	●	○	●	●	Software error (IORSTL)

●:On, ○:Off

\*3 These LEDs turn on, turn off, or flash according to the operating status.

No.1 to 4 are checked only at the time of the reset.

Transmission is performed only when an EEPROM error occurs.

## 6.2 LJ51AW12D2

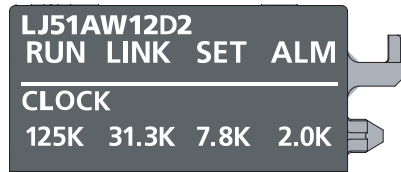

Name		Color	Meaning	
RUN LED		Green	On	Operating normally
			Off	Master module error, 5VDC power off, CPU module stop error
LINK LED		Green	Flashing	Data link can be performed.
			Off, on	Data link cannot be performed.
SET LED		Green	On	During automatic address detection operation
			Off	Operating normally
			Flashing	During EEPROM write
ALM LED		Red	On	D/G disconnection, no response from the slave module
			Slow flashing <sup>*1</sup>	D/24V or D/G short
			Fast flashing <sup>*2</sup>	24VDC is not being supplied, or the voltage is low
			Off	Operating normally
CLOCK LED	125K LED	Green	On	Transmission speed of 125kHz, operating in the 50m mode
			Off	Transmission speed of 125kHz, not in the 50m mode
	31.3K LED	Green	On	Transmission speed of 31.3kHz, operating in the 200m mode
			Off	Transmission speed of 31.3kHz, not in the 200m mode
	7.8K LED	Green	On	Transmission speed of 7.8kHz, operating in the 1km mode
			Off	Transmission speed of 7.8kHz, not in the 1km mode
	2.0K LED	Green	On	Transmission speed of 2.0kHz, operating in the 3km mode
			Off	Transmission speed of 2.0kHz, not in the 3km mode

\*1 "Slow flashing": at approximately one-second intervals

\*2 "Fast flashing": at approximately 0.2-second intervals

# CHAPTER 7 CONNECTIONS

The connection terminals (transmission cable terminal block) for the AnyWire DB A20 transmission cable can be connected and disconnected easily.

The transmission cables and power supply cables are connected using the common terminal block.

## Point

For compliance with the EMC and Low Voltage Directives, refer to Page 73, Appendix 1.

Even when the compliance with the EMC and Low Voltage Directives is not required, use of an EMC-compliant configuration may reduce the influence from external noise.

## 7.1 Description of Terminals

Terminal	Description
D	AnyWire DB A20 transmission signal terminal for the master module D: Transmission cable (+), G: Transmission cable (-)
G	Connect to the D and G terminals to those on the slave module and terminating unit.
24V	Power supply terminal for driving the transmission circuit for the master module Connect a 24VDC stabilized power supply to the 24V and 0V terminals.
0V	
LG	Connect the LG terminal to the neutral point of the noise filter inserted between the 24V and 0V terminals. If malfunctions occur due to the power noise in the 24VDC system, ground the LG terminal with the functional ground terminal (FG terminal) on the programmable controller at a single point.

For details on connections to the D and G terminals on the slave module and terminating unit, refer to the relevant manuals of each product.

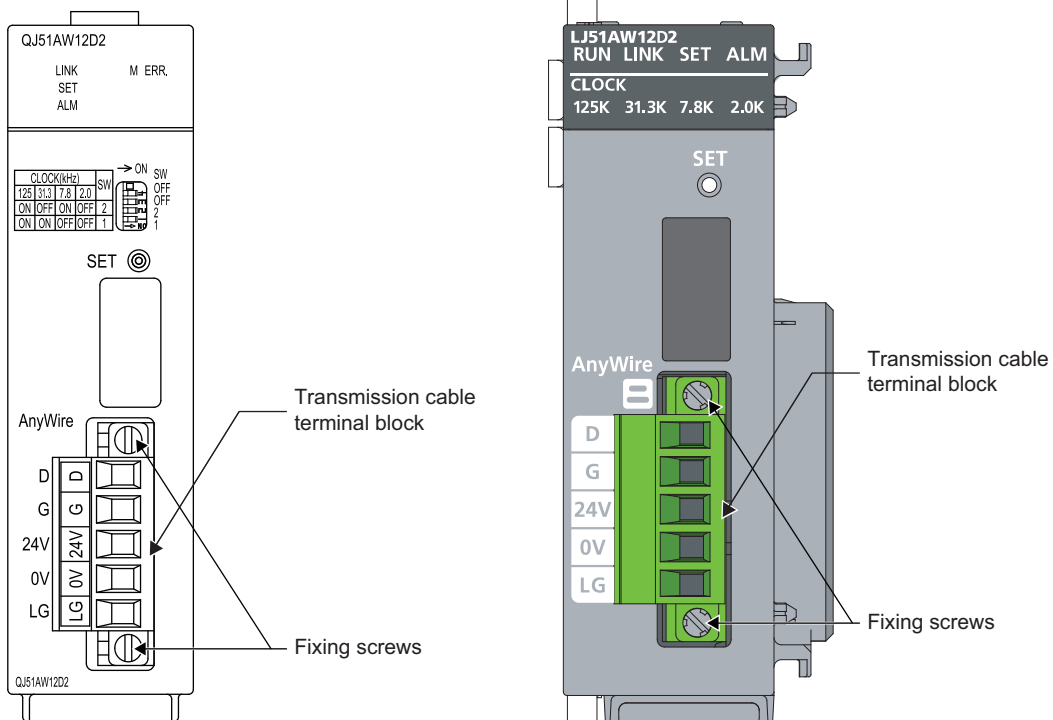

## 7.2 Transmission Cable Terminal Block

---

Manufacturer: Phoenix Contact Co., Ltd. (Contact: [www.phoenixcontact.com](http://www.phoenixcontact.com))

Model: MSTB2,5/5-STF-5,08AU

Tightening torque: 0.2 to 0.3 N·m

To tighten the connector, a flathead screwdriver having a tipped size of  $0.4 \times 2.5\text{mm}$  is required.

Before removing the transmission cable terminal block, check that the fixing screws on both sides are completely loosened (removed from the socket).

Pulling with excessive force while the screws are still tightened may cause damage to the devices.

Before tightening the terminal block, check that there are no short-circuits due to the disconnected or frayed wires and tighten the screws at both ends securely. (Tightening torque: 0.2 to 0.3N·m)

## 7.3 Cable Processing

Bare cables can be connected to the transmission cable terminal block; however, for safety reasons, it is recommended to connect the crimped bar terminals.

For wiring, use the connection cables as listed in Page 20, Section 2.2.1 and tighten them with the applicable tightening torque.

Use UL-listed solderless terminals and, for processing, use a tool recommended by their manufacturer.

[Recommended bar terminals (manufactured by Phoenix Contact Co., Ltd.)]

- For processing a 0.75mm<sup>2</sup> wire: AI 0,75-8 GY
- For processing a 1.25mm<sup>2</sup> wire: AI 1,5-8 BK
- For processing a 2mm<sup>2</sup> wire: AI 2,5-8 BU or others
- For processing two 0.75mm<sup>2</sup> wires: AI-TWIN 2 × 0,75-8 GY
- For processing two 1.25mm<sup>2</sup> wires: AI-TWIN 2 × 1,5-8 BK

When connecting two wires to one terminal, connect the two wires together to the TWIN bar terminal.

When TWIN bar terminals are used for this transmission cable terminal block, the maximum wire diameter is 1.25mm<sup>2</sup>. For details on sizes other than those listed above and crimping tools, refer to the catalog or website of Phoenix Contact Co., Ltd.

### Point

- Do not run multiple transmission cables (D, G) using a multicore cable.

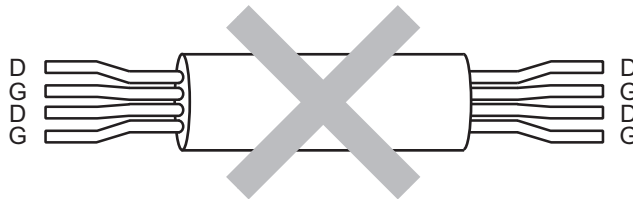

- Use the following line diameters for the transmission cables.
  - 200m or shorter: 0.75mm<sup>2</sup> to 1.25mm<sup>2</sup>
  - 200m or longer: 0.9mm<sup>2</sup> to 1.25mm<sup>2</sup>
- The voltage should not fall below the lower limit of the allowable voltage range due to the voltage drop caused by the cable.
  - If the voltage falls below the lower limit, malfunctions may occur.
  - If the voltage falls substantially, install the external power supply.
  - For installing the external power supply, refer to the "AnyWire DB A20 Series Technical Manual" (manufactured by Anywire Corporation).
- Do not connect soldered cables directly to the terminals. Doing so may loosen the screws, resulting in a poor contact.

# 7.4 Terminating Unit

To ensure more stable transmission quality, connect a terminating unit (AT2 manufactured by Anywire Corporation) to the end of the transmission line.

## Terminating unit connection

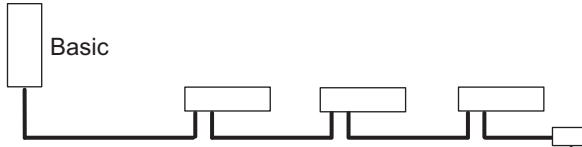

**Important** Connect a terminating unit at the end of a line for one master module.

Transmission distance	50m (total length)
	200m (total length)
	1km (total length)
	3km (total length)

The setting applies to all the transmission speeds.

## Branch of transmission cables (transmission distance: 1km)

[Example]

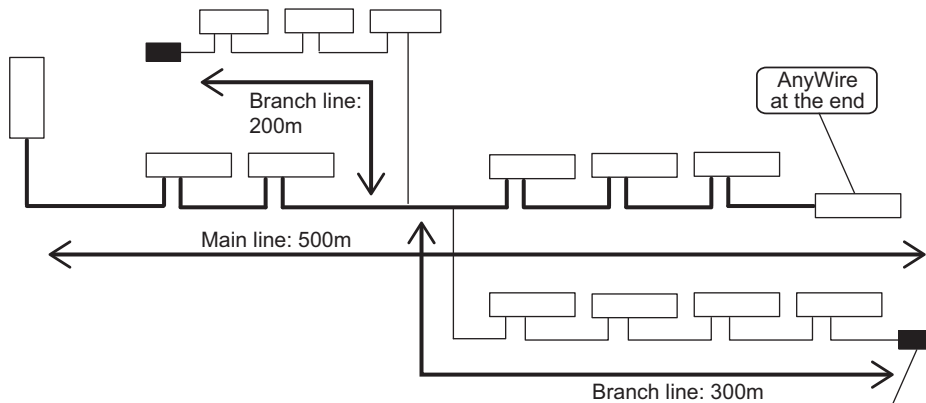

**Important** Connect one terminating unit at the end of a branch line that exceeds 200m. Contact us if more than two branch lines exceed 200m.

## Total length

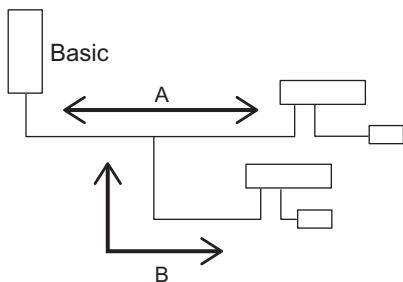

The total length of the transmission distance for the AnyWire DB A20 can be calculated from A + B. Note that the total length should not exceed the maximum transmission distance set for the system to branch lines.

# CHAPTER 8 TRANSMISSION TIME

This section describes the transmission cycle time and transmission delay time of AnyWire DB A20.

## 8.1 Transmission Cycle Time

The transmission cycle time is the time required for the master module and all the slave modules to update I/O data.

### 8.1.1 Transmission cycle time of the master module

The transmission cycle time of the master module is listed in the table below.

Maximum number of transmission points setting	Transmission cycle time (ms)			
	125kHz	31.3kHz	7.8kHz	2kHz
	(50m)	(200m)	(1km)	(3km)
64 points (32 points × 2)	0.42	1.7	6.8	24.8
128 points (64 points × 2)	0.7	2.7	10.9	40.7
256 points (128 points × 2)	1.2	4.8	19.1	72.4
384 points (192 points × 2)	1.7	6.8	27.3	104.2
512 points (256 points × 2)	2.2	8.9	35.5	135.9
640 points (320 points × 2)	2.7	10.9	43.6	167.6
768 points (384 points × 2)	3.2	13.0	51.8	199.4
896 points (448 points × 2)	3.8	15.0	60.0	231.1
1024 points (512 points × 2)	4.3	17.1	68.2	262.9
2048 points (1024 points × 2)	8.4	33.4	133.8	516.8

## 8.1.2 Effects of the double check system

### (1) Input

On the master module side, if the same data is not repeated twice in continuance, the input area data is not updated (double check). Therefore, a minimum of one transmission cycle time and a maximum of two transmission cycle times are required for the data response time.

Therefore, signals of two-transmission cycle time or less may not be captured depending on the timing.

To ensure the response to the input signal, provide an input signal that is longer than two-transmission cycle time.

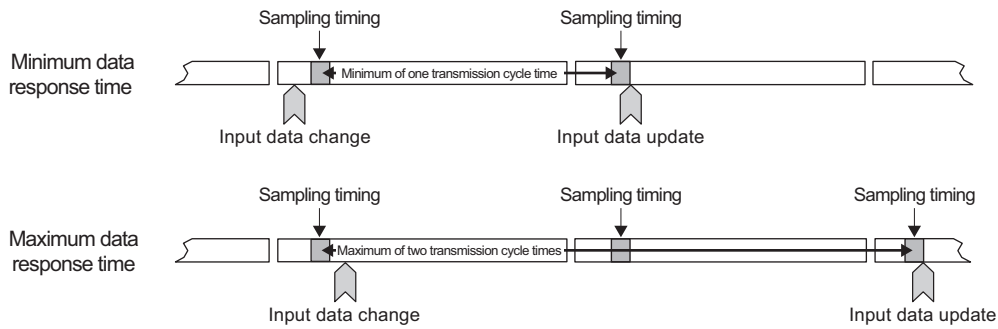

### (2) Output

As the double check is performed on the slave module side, the time required is the same as that for input, namely a minimum of one-transmission cycle time and a maximum of two-transmission cycle time.



## 8.2 Transmission Delay Time

This section describes the transmission delay time (time until data is transmitted).

### 8.2.1 Slave module (input) to master module

The figure below shows the time between a signal input to the slave module and the CPU module device (X) turning on/off.

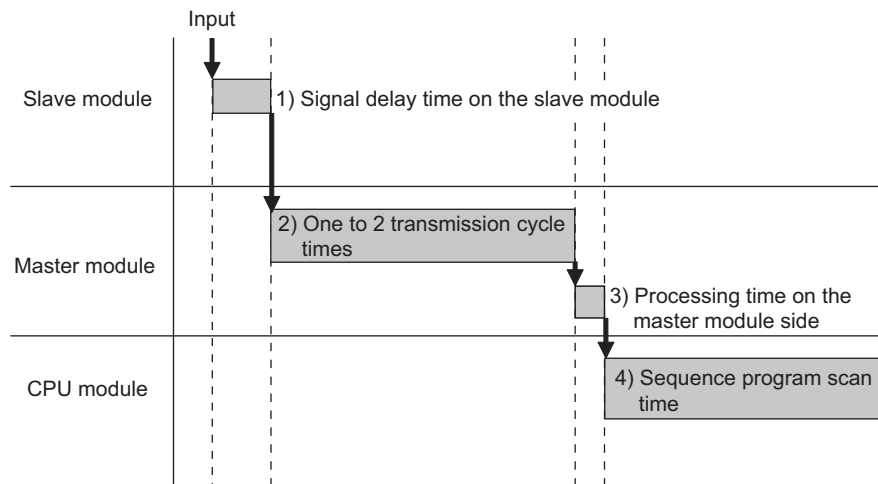

[Calculation formula]

1) Signal delay time of the slave module + 2) Transmission cycle time  $\times$  2 + 3) Processing time on the master module side + 4) Sequence program scan time  $\times$  2 [ms]

[Calculation example]

1) Signal delay time of the slave module

Signal delay time of the slave module is 0.17ms: 0.17 [ms]

2) Transmission cycle time  $\times$  2

When the transmission point is set to 1024 and the transmission speed is set to 31.3kHz:  $17.1 \times 2 = 34.2$  [ms]

3) Processing time on the master module side

Processing time on the master module side = Transmission speed clock width  $\times$  16

When the transmission speed is set to 31.3kHz:  $(1 \div 31.3k) \times 16 = 0.511$  [ms]

4) Sequence program scan time  $\times$  2

Set the sequence program scan time to 5ms:  $5 \times 2 = 10$  [ms]

Therefore, the transmission delay time is  $0.17 + 34.2 + 0.511 + 10 = 44.88$  [ms].

## 8.2.2 Master module to slave module (output)

The figure below shows the time between the CPU module device (Y) turning on/off and a signal output from the slave module turning on/off.

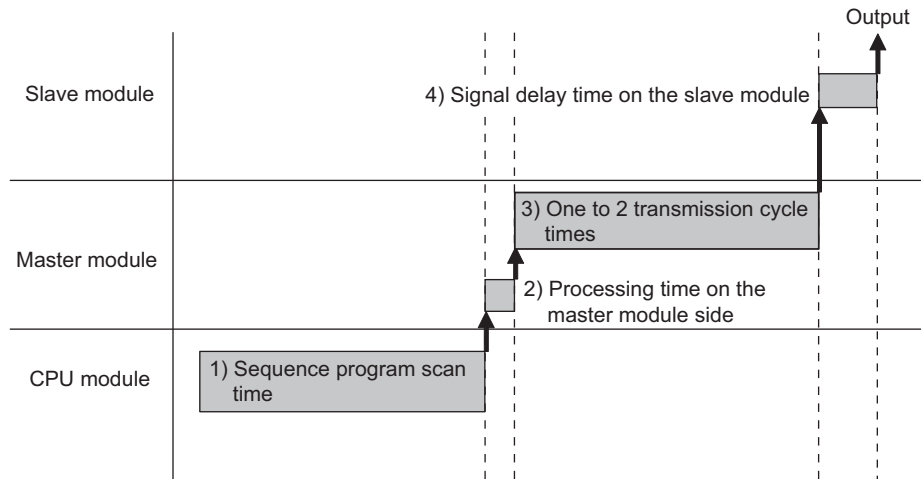

[Calculation formula]

1) Sequence program scan time + 2) Processing time on the master module side + 3) Transmission cycle time  $\times$  2 + 4) Signal delay time of the slave module [ms]

[Calculation example]

1) Sequence program scan time

Set the sequence program scan time to 5ms: 5 [ms]

2) Processing time on the master module side

Processing time on the master module side = Transmission speed clock width  $\times$  16

When the transmission speed is set to 31.3kHz:  $(1 \div 31.3k) \times 16 = 0.511$  [ms]

3) Transmission cycle time  $\times$  2

When the transmission point is set to 1024 and the transmission speed is set to 31.3kHz:  $17.1 \times 2 = 34.2$  [ms]

4) Signal delay time of the slave module

Signal delay time of the slave module is 0.01ms: 0.01 [ms]

Therefore, the transmission delay time is  $5 + 0.511 + 34.2 + 0.01 = 39.72$  [ms].

# CHAPTER 9 TROUBLESHOOTING

If the transmission does not start normally, check the following items and perform the troubleshooting.

- All devices are being supplied with 24VDC power supply.
- The "LINK" LEDs of all the AnyWire DB A20 slave modules are flashing.
- The address settings are correct and unique.

For details on the entire AnyWire DB A20 system, refer to the "AnyWire DB A20 Series Technical Manual" (manufactured by Anywire Corporation).

## 9.1 Visual Inspection

Check that the communication cables and wires are not disconnected and check the following items.

### (1) Checking the LED status of the master module

Errors regarding the operating status and communications of the master module can be checked with the following LEDs. When the LEDs are in the following status, settings and wiring need to be corrected.

#### (a) QJ51AW12D2

##### 1. Check the M.ERR LED of the master module.

If the M ERR. LED is on, perform the following troubleshooting.

☞ Page 68, Section 9.3.1 (1)

##### 2. Check the LINK LED of the master module.

If the LINK LED does not flash, perform the following troubleshooting.

☞ Page 68, Section 9.3.1 (2)

##### 3. Check the ALM LED of the master module.

If the ALM LED is flashing at 0.2-second intervals, perform the following troubleshooting.

☞ Page 68, Section 9.3.1 (3)

If the ALM LED is flashing at 1 second intervals, perform the following troubleshooting.

☞ Page 68, Section 9.3.1 (4)

If the ALM LED is on, perform the following troubleshooting.

☞ Page 69, Section 9.3.1 (5)

## (b) LJ51AW12D2

### 1. Check the LINK LED of the master module.

If the LINK LED does not turn on or flash even after power-on, perform the following troubleshooting.

☞ Page 69, Section 9.3.2 (1)

If the LINK LED does not flash, perform the following troubleshooting.

☞ Page 69, Section 9.3.2 (2)

### 2. Check the ALM LED of the master module.

If the ALM LED is flashing at 0.2-second intervals, perform the following troubleshooting.

☞ Page 69, Section 9.3.2 (3)

If the ALM LED is flashing at 1 second intervals, perform the following troubleshooting.

☞ Page 70, Section 9.3.2 (4)

If the ALM LED is on, perform the following troubleshooting.

☞ Page 70, Section 9.3.2 (5)

### 3. Check the RUN LED of the master module.

If the RUN LED does not turn on, perform the following troubleshooting.

☞ Page 70, Section 9.3.2 (6)

## (2) Checking the status of the slave module

Check that there is no error in the slave module.

For the troubleshooting of the slave module, refer to the following.

☞ Page 71, Section 9.4

- When the data (I/O data and parameter data) of the slave module cannot be checked
- When the data (I/O data and parameter data) of the slave module data is unstable

## 9.2 Check with Input Signals

### (1) If D/G terminal short (Xn1) is on

If D/G terminal short (Xn1) is on, perform the following troubleshooting.

- QJ51AW12D2 (☞ Page 68, Section 9.3.1 (4))
- LJ51AW12D2 (☞ Page 70, Section 9.3.2 (4))

### (2) If D/24V terminal short (Xn2) is on

If D/24V terminal short (Xn2) is on, perform the following troubleshooting.

- QJ51AW12D2 (☞ Page 68, Section 9.3.1 (4))
- LJ51AW12D2 (☞ Page 70, Section 9.3.2 (4))

### (3) If 24V not applied (Xn3) is on

If 24V not applied (Xn3) is on, perform the following troubleshooting.

- QJ51AW12D2 (☞ Page 68, Section 9.3.1 (3))
- LJ51AW12D2 (☞ Page 69, Section 9.3.2 (3))

### (4) If D/G terminal disconnection (Xn4) is on

If D/G terminal disconnection (Xn4) is on, perform the following troubleshooting.

- QJ51AW12D2 (☞ Page 69, Section 9.3.1 (5))
- LJ51AW12D2 (☞ Page 70, Section 9.3.2 (5))

## 9.3 Troubleshooting of Master Module

This section describes the troubleshooting of the master module.

### 9.3.1 QJ51AW12D2

#### (1) The M ERR. LED on the master module is on.

Item	Action
Check that the supply power to the programmable controller system is within the specifications.	If the M ERR. LED does not turn off after powering on the master module, hardware failure may have occurred. Please consult your local Mitsubishi representative.
Check that a hardware failure or a watchdog timer error has not occurred.	

#### (2) The LINK LED on the master module does not flash.

Item	Action
Check that the LINK LED is off.	A malfunction has been detected in the master module hardware. Reset the master module. If the error occurs again, the module may be in failure. Please consult your local Mitsubishi representative.

#### (3) The ALM LED on the master module is flashing at 0.2 second intervals.

Item	Action
Check the power supply voltage of the external power supply.	Adjust the power supply voltage of the external power supply which is connected to the master module to be within the rated value (21.6 to 27.6VDC).
Check that the power cables are not short-circuited.	Check that the power cables (24V, 0V) are not disconnected or short-circuited. When crimping the link connector, check that the pin assignment is correct.
Check the wiring of the terminal blocks.	Check that the external power supply is properly connected to the terminal block of the master module or the slave module. Check that there is no short-circuit or incorrect wiring and screws are tightened sufficiently.

#### (4) The ALM LED on the master module is flashing at 1 second intervals.

Item	Action
Check that the signal wire of the transmission cable (D-G or D-24V) is not short-circuited.	Check that the transmission cables are not short-circuited. When crimping the link connector, check that the pin assignment is correct.
Check the wiring of the terminal blocks.	Check that the transmission cables are not in contact with each other and that there is no incorrect wiring in the terminal block wiring of the master module and the slave module.

**(5) The ALM LED on the master module is on.**

Item	Action
Check that the signal wire of transmission cable (D or G) is not short-circuited.	Check that the transmission cables (entire cables) are free from disconnection. Also check that the cables have been crimped with proper pin assignment using link connectors appropriate to the wire diameter.
Check the wiring of terminal blocks.	Check that the signal cables are properly connected to the terminal block of the master module. In addition, check that there is no incorrect wiring and that screws are tightened sufficiently.
Perform the automatic address detection operation.	When creating a new system, adding or removing a slave module, or changing the address of the slave module, perform the automatic address detection operation. After the operation ends, check that the number of slave modules and the address are consistent with those of the actual system.
Check the existence of the slave module.	If the LINK LED of the slave module does not flash, check that there is no disconnection, short-circuit, incorrect wiring, or poor contact in the transmission cables around the module.

**9.3.2 LJ51AW12D2****(1) When the LINK LED does not turn on or flash after power-on**

Item	Action
Check the power supply voltage.	Check that the power supply voltage of the external power supply is within the rated value.
Check the wiring of the terminal blocks.	Check that the external power supply is properly connected to the terminal block of the master module. Check that there is no short-circuit or incorrect wiring and screws are tightened sufficiently.
Check that the power cables are not short-circuited.	Check that the power cables (24V, 0V) are not disconnected or short-circuited. When crimping the link connector, check that the pin assignment is correct.
Check the total internal current consumption of the entire system.	Review the system configuration so that the total internal current consumption does not exceed the rated output current of the power supply module.

**(2) The LINK LED on the master module does not flash.**

Item	Action
Check that the LINK LED is turned on.	A malfunction has been detected in the master module hardware. Reset the master module. If the error occurs again, the module may be in failure. Please consult your local Mitsubishi representative.

**(3) The ALM LED on the master module is flashing at 0.2 second intervals.**

Item	Action
Check the power supply voltage of the external power supply.	Adjust the power supply voltage of the external power supply which is connected to the master module to be within the rated value (21.6 to 27.6VDC).
Check that the power cables are not short-circuited.	Check that the power cables (24V, 0V) are not disconnected or short-circuited. When crimping the link connector, check that the pin assignment is correct.
Check the wiring of the terminal blocks.	Check that the external power supply is properly connected to the terminal block of the master module or the slave module. Check that there is no short-circuit or incorrect wiring and screws are tightened sufficiently.

**(4) The ALM LED on the master module is flashing at 1 second intervals.**

Item	Action
Check that the signal wire of the transmission cable (D-G or D-24V) is not short-circuited.	Check that the transmission cables are not short-circuited. When crimping the link connector, check that the pin assignment is correct.
Check the wiring of the terminal blocks.	Check that the transmission cables are not in contact with each other and that there is no incorrect wiring in the terminal block wiring of the master module and the slave module.

**(5) The ALM LED on the master module is on.**

Item	Action
Check that the signal wire of transmission cable (D or G) is not short-circuited.	Check that the transmission cables (entire cables) are free from disconnection. Also check that the cables have been crimped with proper pin assignment using link connectors appropriate to the wire diameter.
Check the wiring of terminal blocks.	Check that the signal cables are properly connected to the terminal block of the master module. In addition, check that there is no incorrect wiring and that screws are tightened sufficiently.
Perform the automatic address detection operation.	When creating a new system, adding or removing a slave module, or changing the address of the slave module, perform the automatic address detection operation. After the operation ends, check that the number of slave modules and the address are consistent with those of the actual system.
Check the existence of the slave module.	If the LINK LED of the slave module does not flash, check that there is no disconnection, short-circuit, incorrect wiring, or poor contact in the transmission cables around the module.

**(6) The RUN LED on the master module does not turn on.**

Item	Action
Check that the supply power to the programmable controller system is within the specifications.	If the RUN LED does not turn on after powering on the master module, hardware failure may have occurred. Please consult your local Mitsubishi representative.
Check that a hardware failure or a watchdog timer error has not occurred.	



## 9.4 Troubleshooting of Slave Module

This section describes the troubleshooting of the slave module.

### (1) When I/O data and parameter data cannot be checked

Item	Action
Check the FROM/TO instruction issued by the program using the programming tool.	<ul style="list-style-type: none"> <li>• Check that the buffer memory map of the programmable controller device and the master module assigned by the MOV instruction or the FROM/TO instruction is appropriate.</li> <li>• Check that the programmable controller CPU is in the STOP state. Slave module cannot output when the programmable controller CPU is in the STOP state.</li> </ul>
Check that the LINK LED on the slave module is flashing.	<p>If the LINK LED of the slave module does not flash, check that there is no disconnection, short-circuit, incorrect wiring, or poor contact in the transmission cables around the module.</p> <p>In addition, check that the transmission speed setting of the slave module is same as that of the master module.</p>
Check that the RDY LED on the slave module is on.	<p>If the RDY LED on the slave module does not turn on, a power supply error has occurred.</p> <p>Possible causes are disconnection of the power cable, short-circuit, and shortage of the power supply voltage.</p> <p>Check the wiring, installation method, and power supply voltage of the slave module.</p>

### (2) When the I/O data and parameter data of the slave module is unstable

Item	Action
Check the connection of the terminating unit.	Pay attention to the polarities of the terminating unit (AT2) and connect it correctly.
Check the total length of the transmission cables.	Adjust the total length of the AnyWire DB A20 system to be within the specification range.
Check the type of the transmission cables.	Check that the transmission cables have the specified type, wire diameter, and tightening torque to the terminal block. Do not run multiple transmission cables (D, G) using a multicore cable.
Check the voltage range of the external power supply.	Adjust the power supply voltage of the external power supply to be within the rated value (21.6 to 27.6VDC).
Check that the slave module does not have the same address as the addresses of other slave modules.	Set a unique address in the slave module.
Check the FROM/TO instruction issued by the program using the programming tool.	Check that the buffer memory map of the programmable controller device and the master module assigned by the MOV instruction or the FROM/TO instruction is appropriate.

## 9.5 List of Error Codes

This section lists the error codes of the master module.

Error code	Error description	Action
0064 <sub>H</sub> to 0067 <sub>H</sub>	Master module hardware error	A malfunction has been detected in the master module hardware. Reset the CPU module. If the error occurs again, the master module may be in failure. Please consult your local Mitsubishi representative.
0068 <sub>H</sub>	CPU module stop error	A stop error has occurred in the CPU module. Check and correct the error using PLC Diagnostics of the programming tool.
00C8 <sub>H</sub>	Transmission cable voltage drop error	The voltage of the 24VDC external power supply may be lacking. Perform the following. <ul style="list-style-type: none"> <li>Adjust the power supply voltage of the 24VDC external power supply to be within the rated value (21.6 to 27.6VDC).</li> <li>Check that the power cables (24V, 0V) are not disconnected or short-circuited. When crimping the link connector, check that the pin assignment is correct.</li> <li>Check that the 24VDC external power supply is properly connected to the terminal block of the master module or the slave module.</li> <li>Check that there is no short-circuit or incorrect wiring and screws are tightened sufficiently.</li> </ul>
00C9 <sub>H</sub>	Short between D and G terminals	The transmission cables (D, G) may have short-circuited. Perform the following. <ul style="list-style-type: none"> <li>Check that the transmission cables (D, G) are not short-circuited. When crimping the link connector, check that the pin assignment is correct.</li> <li>Check that the transmission cables (D, G) are not in contact with each other and that there is no incorrect wiring in the terminal block wiring of the master module and the slave module.</li> </ul>
00CA <sub>H</sub>	D, G disconnection error	The transmission cables (D, G) may have been disconnected or there may be no response from the slave module. The slave module may be malfunctioning or the system configuration may have been changed after the automatic address detection function is executed. Check Number of the error IDs (Un\G8192) and Error ID information storage area (Un\G8193 to Un\G8320) of the buffer memory to locate the disconnected cable and perform the following. <ul style="list-style-type: none"> <li>Check that the transmission cables (entire cables) are free from disconnection. Also check that the cables have been crimped with proper pin assignment using link connectors appropriate to the wire diameter.</li> <li>Check that the signal cables are properly connected to the terminal block of the master module. In addition, check that there is no incorrect wiring and that screws are tightened sufficiently.</li> <li>When creating a new system, adding or removing a slave module, or changing the address of the slave module, perform the automatic address detection function. After executing the automatic address detection function, check that the number of slave modules and the address are consistent with those of the actual system.</li> <li>If the LINK LED on the slave module does not flash, check that there is no disconnection, short-circuit, incorrect wiring, or poor contact in the transmission cables (D, G) around the module.</li> </ul>
00CB <sub>H</sub>	D-24 V short error	The transmission cables (D, 24V) may have short-circuited. Perform the following. <ul style="list-style-type: none"> <li>Check that the transmission cables (D, 24V) are not short-circuited. When crimping the link connector, check that the pin assignment is correct.</li> <li>Check that the transmission cables (D, 24V) are not in contact with each other and that there is no incorrect wiring in the terminal block wiring of the master module and the slave module.</li> </ul>

### Point

Check the error information with Latest error code storage area (2810<sub>H</sub>) and Latest error ID storage area (2811<sub>H</sub>) of the buffer memory.

# APPENDICES

---

## Appendix 1 EMC and Low Voltage Directives

---

Compliance with the EMC Directive, which is one of the EU directives, has been mandatory for the products sold within EU member states since 1996 as well as compliance with the Low Voltage Directive since 1997.

To prove the compliance with these Directives, manufacturers must issue an EC Declaration of Conformity and the products must bear a CE marking.

### (1) Sales representative in EU member states

The sales representative in EU member states will be:

Name: Mitsubishi Electric Europe BV

Address: Gothaer Strasse 8, 40880 Ratingen, Germany

## Appendix 1.1 Requirements for compliance with the EMC Directive

---

The EMC Directive sets two requirements for compliance: emission (conducted and radiated electromagnetic energy emitted by a product) and immunity (the ability of a product to function without being influenced by externally generated electromagnetic energy), and all applicable products are required to satisfy these requirements. This section summarizes the precautions for machinery constructed with this product to comply with the EMC Directive.

These precautions are based on the requirements of the EMC Directive and the harmonized standards. However, they do not guarantee that the entire machinery constructed according to the descriptions complies with the EMC Directive. The manufacturer of the machinery must determine the testing method for compliance and declare conformity to the EMC Directive.

## (1) Installation in control panel

This open-type device is intended to be placed in an industrial control panel or similar type of enclosure.\*1

This ensures safety as well as effective shielding of electromagnetic noise emitted from this product.

\*1 Modules on the remote station in each network must be also installed inside the control panel.  
However, waterproof modules on the remote station can be installed outside the control panel.

### (a) Control panel

- Use a conductive control panel.
- Mask off the area used for grounding when securing the top or bottom plate to the control panel using bolts.
- To ensure electrical contact between the inner plate and the control panel, mask off the bolt installation areas of an inner plate so that conductivity can be ensured in the largest possible area.
- Ground the control panel with a thick ground cable so that low impedance can be ensured even at high frequencies.
- Keep the diameter of the holes in the control panel 10cm or less. If the diameter is larger than 10cm, electromagnetic wave may be emitted. In addition, because electromagnetic wave leaks through a clearance between the control panel and its door, reduce the clearance as much as possible. The leakage of radio waves can be suppressed by the direct application of an EMI gasket on the paint surface.

The tests by Mitsubishi were conducted using a panel having the damping characteristics of 37dB (maximum) and 30db (average) (measured at 3m distance, 30 to 300MHz).

### (b) Wiring power and ground cables

Run the ground cable and the power cable of this product as instructed below.

- Provide a ground point to the control panel near the power supply module. Ground the LG (line ground) and FG (frame ground) terminals of the power supply module for the programmable controller and the LG terminal of the transmission cable terminal block to the ground point with the thickest and shortest ground cable possible (about 30cm or shorter). Because the LG and FG terminals serve to dissipate noise generated within the programmable controller to the ground, the impedance of the ground cable must be as low as possible. In addition, the ground cable must be kept as short as possible. The ground cable serves to dissipate noise. Because the ground cable itself bear noise, keeping the cable short means that the cable prevents itself from being an antenna.
- The ground cable run from the contact point must be twisted with the power cable. By twisting the power cable with the ground cable, more noise flowing through the power cable can be dissipated to the ground. However, when a noise filter is attached to the power cable, twisting with the ground cable may be unnecessary.

## (2) Cables

### (a) Cable connected to the transmission cable terminal block

For the cable connected to the transmission cable terminal block, attach a ferrite core having the attenuation characteristics equivalent to that of ZCAT3035-1330 made by TDK Corporation as close to the transmission cable terminal block of this product as possible. Use a ferrite core with three turns of wire as shown below.

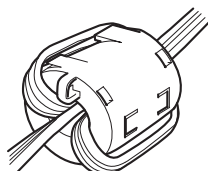

### (b) Power cable for the 24VDC power supply terminal

Use a CE-marked DC power supply. The DC power supply must be placed together with the module in the same control panel, and the power cable connected to the power terminal of this product should be 30cm or shorter.

## (3) External power supply

Use a CE-marked external power supply and ground the FG terminal.

(External power supply used for the tests conducted by Mitsubishi: PS5R-SF24 made by IDEC Corporation)

## (4) Power supply module for the programmable controller

Ground the LG and FG terminals after short-circuiting them.

## (5) Installation environment

Use this product in Zone B\*<sup>1</sup>.

- \*1 Zone means a category determined according to the industrial environment conditions and defined by the harmonized standard EN61131-2 of the EMC and Low Voltage Directives.
- Zone C: Main power supply insulated from the public power supply by a special transformer
  - Zone B: Special power supply with the secondary surge protector from the main power (Rated voltage is assumed to be 300V or less.)
  - Zone A: Local power supply protected by an AC-DC converter or an insulating transformer from the special power supply (Rated voltage is assumed to be 120V or less.)

# Appendix 1.2 Requirements for compliance with the Low Voltage Directive

The Low Voltage Directive does not apply to this product because it operates on 5VDC and 24VDC power supply. For making the PLC system used comply with the Low Voltage Directive, refer to the manual supplied with the CPU module, the base unit, or the head module.

## Appendix 2 Differences between the QJ51AW12D2 and LJ51AW12D2

---

This section describes the differences between the QJ51AW12D2 and LJ51AW12D2.

Item	Difference	
	QJ51AW12D2	LJ51AW12D2
Error diagnostics using system monitor of the programming tool	Disabled	Enabled
Operation at recovery from error (24V power supply drop, short circuit of signal cables)	Error flags are automatically cleared. Error clear is not required after recovery from error.	Error flags are maintained. Error clear is required after recovery from error.

## Appendix 3 Functions Added and Modified with Version Upgrade

A

The master module has some new functions added and specifications modified as a result of a version upgrade. The functions and specifications that can be used in the master module vary depending on the function version and the serial number.

Additional functions	Module	Supported function version	Sixth digit of the serial number
<ul style="list-style-type: none"> <li>• Double check mode, waveform output method (☞ Page 31, Section 3.1.2)</li> <li>• Addition of buffer memory area (☞ Page 46, Section 4.2)</li> </ul>	QJ51AW12D2	B	"6" or later

# REVISIONS

\*The manual number is given on the bottom left of the back cover.

Print date	*Manual number	Revision
February 2011	SH(NA)-080968ENG-A	First edition
May 2011	SH(NA)-080968ENG-B	Revision due to error correction
March 2013	SH(NA)-080968ENG-C	Revision due to compliance with EMC and UL/cUL
October 2014	SH(NA)-080968ENG-D	Revision due to the addition of the LJ51AW12D2 and function for the QJ51AW12D2, and compliance with UL/cUL of the LJ51AW12D2

Japanese manual version SH-080967-E

This manual confers no industrial property rights or any rights of any other kind, nor does it confer any patent licenses. Mitsubishi Electric Corporation cannot be held responsible for any problems involving industrial property rights which may occur as a result of using the contents noted in this manual.

© 2011 MITSUBISHI ELECTRIC CORPORATION



# WARRANTY

Please confirm the following product warranty details before using this product.

## **1. Gratis Warranty Term and Gratis Warranty Range**

If any faults or defects (hereinafter "Failure") found to be the responsibility of Mitsubishi occurs during use of the product within the gratis warranty term, the product shall be repaired at no cost via the sales representative or Mitsubishi Service Company.

However, if repairs are required onsite at domestic or overseas location, expenses to send an engineer will be solely at the customer's discretion. Mitsubishi shall not be held responsible for any re-commissioning, maintenance, or testing on-site that involves replacement of the failed module.

[Gratis Warranty Term]

The gratis warranty term of the product shall be for one year after the date of purchase or delivery to a designated place. Note that after manufacture and shipment from Mitsubishi, the maximum distribution period shall be six (6) months, and the longest gratis warranty term after manufacturing shall be eighteen (18) months. The gratis warranty term of repair parts shall not exceed the gratis warranty term before repairs.

[Gratis Warranty Range]

- (1) The range shall be limited to normal use within the usage state, usage methods and usage environment, etc., which follow the conditions and precautions, etc., given in the instruction manual, user's manual and caution labels on the product.
- (2) Even within the gratis warranty term, repairs shall be charged for in the following cases.
  1. Failure occurring from inappropriate storage or handling, carelessness or negligence by the user. Failure caused by the user's hardware or software design.
  2. Failure caused by unapproved modifications, etc., to the product by the user.
  3. When the Mitsubishi product is assembled into a user's device, Failure that could have been avoided if functions or structures, judged as necessary in the legal safety measures the user's device is subject to or as necessary by industry standards, had been provided.
  4. Failure that could have been avoided if consumable parts (battery, backlight, fuse, etc.) designated in the instruction manual had been correctly serviced or replaced.
  5. Failure caused by external irresistible forces such as fires or abnormal voltages, and Failure caused by force majeure such as earthquakes, lightning, wind and water damage.
  6. Failure caused by reasons unpredictable by scientific technology standards at time of shipment from Mitsubishi.
  7. Any other failure found not to be the responsibility of Mitsubishi or that admitted not to be so by the user.

## **2. Onerous repair term after discontinuation of production**

- (1) Mitsubishi shall accept onerous product repairs for one year after production of the product is discontinued. Discontinuation of production shall be notified with Mitsubishi Technical Bulletins, etc.
- (2) Product supply (including repair parts) is not available after production is discontinued.

## **3. Overseas service**

Overseas, repairs shall be accepted by Mitsubishi's local overseas FA Center. Note that the repair conditions at each FA Center may differ.

## **4. Exclusion of loss in opportunity and secondary loss from warranty liability**

Regardless of the gratis warranty term, Mitsubishi shall not be liable for compensation of damages caused by any cause found not to be the responsibility of Mitsubishi, loss in opportunity, lost profits incurred to the user by Failures of Mitsubishi products, special damages and secondary damages whether foreseeable or not, compensation for accidents, and compensation for damages to products other than Mitsubishi products, replacement by the user, maintenance of on-site equipment, start-up test run and other tasks.

## **5. Changes in product specifications**

The specifications given in the catalogs, manuals or technical documents are subject to change without prior notice.

## TRADEMARKS

Microsoft, Windows, Windows Vista, Windows NT, Windows XP, Windows Server, Visio, Excel, PowerPoint, Visual Basic, Visual C++, and Access are either registered trademarks or trademarks of Microsoft Corporation in the United States, Japan, and other countries.

Intel, Pentium, and Celeron are either registered trademarks or trademarks of Intel Corporation in the United States and other countries.

Ethernet is a registered trademark of Xerox Corp.

The SD and SDHC logos are either registered trademarks or trademarks of SD-3C, LLC.

All other company names and product names used in this manual are either trademarks or registered trademarks of their respective companies.





**Anywire** Anywire Corporation <http://www.anywire.jp>

SH(NA)-080968ENG-D(1410)MEE

MODEL: QJ51AW12D2-U-E

MODEL CODE: 13JZ52

## **MITSUBISHI ELECTRIC CORPORATION**

HEAD OFFICE : TOKYO BUILDING, 2-7-3 MARUNOUCHI, CHIYODA-KU, TOKYO 100-8310, JAPAN  
NAGOYA WORKS : 1-14, YADA-MINAMI 5-CHOME, HIGASHI-KU, NAGOYA, JAPAN

When exported from Japan, this manual does not require application to the  
Ministry of Economy, Trade and Industry for service transaction permission.

Specifications subject to change without notice.